

# 4R/6R 1000

Operating Instructions



*Power. Passion. Partnership.*

## Symbols

### **WARNING**

Warning notes make you aware of dangers which could pose a threat to your health or life, or to the health and life of others.

### **Environmental note**

Environmental notes provide you with information on environmentally aware actions or disposal.

**!** The purpose of material damage warnings is to draw your attention to risks which could lead to damage to your engine system.

**i** These symbols indicate useful instructions or further information that could be helpful to you.

▶ This symbol designates an instruction you must follow.

▶ Several consecutive symbols indicate an instruction with several steps.

(▷ page) This symbol tells you where you can find further information on a topic.

▷ ▷ This symbol indicates a warning or an instruction that is continued on the next page.

## Welcome

Familiarise yourself with your engine system and read the operating instructions before you use the engine system. This will help you to avoid endangering yourself or others.

The standard equipment and product description of your engine system may vary, depending on individual specifications. This is described on the data card.

The engine systems are constantly updated to be state of the art.

MTU/Mercedes-Benz reserves the right to make changes to the following:

- design
- equipment
- technical features

Descriptions may therefore differ in individual cases from your engine system.

**A**

<b>AdBlue®/DEF</b>	
Consumption .....	37
Gauge .....	29
Important safety notes .....	39
Refuelling .....	39
Service product .....	45
<b>ADM (FR (drive control) unit)</b> .....	9

**B**

<b>Battery (vehicle)</b>	
Jump starting .....	53
<b>Bleeding the fuel system</b>	
Bleeding the prefilter with a hand pump .....	52
<b>Braking</b>	
Continuous brake .....	27
Engine brake .....	27
Retarder .....	27
<b>Buzzer</b> .....	37

**C**

<b>Capacities</b> .....	63
<b>Care products</b> .....	47
<b>Charge current</b> .....	28
<b>Checking the fluid level</b> .....	23
<b>Cleaning and care</b>	
Engine cleaning .....	47
High-pressure cleaning .....	47
Notes on care .....	47
<b>Consumption</b>	
AdBlue®/DEF .....	37
Fuel .....	37
Oil (engine) .....	37
<b>Continuous brake</b>	
Important safety notes .....	27
<b>Coolant</b>	
Mixing ratio .....	43
Service product .....	43
Topping up .....	24
<b>Coolant additive</b> .....	43
<b>Correct use</b> .....	6
<b>Corrosion inhibitor/antifreeze agent</b> .....	43

**D**

<b>Data card</b> .....	60
<b>DEF/AdBlue®</b>	
see AdBlue®/DEF service products	
<b>Description of the engine</b> .....	9
<b>Diagnostics connection</b> .....	20
<b>Diesel</b>	
Fuels .....	44
Low outside temperatures .....	45
Refuelling .....	37
<b>Dimensions</b> .....	61
<b>Disposal of service products</b> .....	42
<b>Driving mode</b>	
Idling speed .....	27
<b>Driving tips</b> .....	36

**E**

<b>Electronic engine control</b>	
see Engine management	
<b>Electronic engine control unit</b> .....	28
<b>Emergency gearshift</b>	
Using the emergency switch .....	28
<b>Emergency running program</b> .....	6
<b>Engine</b>	
Capacities .....	63
Cleaning .....	47
Data .....	61
Data card .....	60
Data plate .....	60
Modifying the power output .....	6
Oil consumption .....	37
Operating data .....	62
Rectifying faults .....	55
Running-in period .....	36
Starting .....	25
Stopping .....	26
<b>Engine brake</b> .....	27
<b>Engine data</b> .....	61
<b>Engine data card</b> .....	60
<b>Engine description</b> .....	9
<b>Engine idling speed</b> .....	27
<b>Engine management</b> .....	15
<b>Engine oil</b>	
Consumption .....	37
For winter operation .....	42
Mixing .....	43

Oil change .....	43
Topping up .....	43
<b>Engine overview</b> .....	10
<b>Engine speed</b> .....	28
<b>Exhaust gas aftertreatment</b> .....	17
<b>Exhaust gas aftertreatment identification plate</b> .....	60

## F

<b>Fuel</b>	
Additives .....	45
Consumption .....	37
Diesel .....	44
Refuelling .....	37
<b>Fuel grade</b> .....	45
<b>Fuel system</b>	
Automatic bleeding .....	52
Manual bleeding .....	52
<b>Fuses</b>	
Checking and replacing a safety fuse .....	53
Important safety notes .....	53

## G

<b>Gauge</b>	
AdBlue®/DEF .....	29
<b>Genuine Mercedes-Benz parts</b> .....	5

## H

<b>High-pressure cleaning</b> .....	47
-------------------------------------	----

## I

<b>Identification plate</b> .....	60
<b>Idling speed</b>	
Engine .....	27
<b>Installation</b> .....	21

## J

<b>Jump-starting</b> .....	53
----------------------------	----

## M

<b>Maintenance</b>	
Notes .....	41

<b>Mercedes-Benz Service Centre</b>	
see Qualified specialist workshop	

## O

<b>Oil (engine)</b>	
For winter operation .....	42
Oil change .....	43
Scope of use .....	42
<b>Oil pressure</b> .....	28
<b>Operating data</b> .....	62
<b>Operating instructions</b>	
General notes .....	8
<b>Operating safety</b> .....	19
<b>Operating safety and registration</b>	
Changes in engine performance .....	6
Implied warranty .....	7
<b>Operational monitoring</b> .....	28
<b>Organisational measures</b> .....	20

## P

<b>Personnel</b> .....	20
<b>Poly-V-belt</b>	
Replacing .....	58
Routing .....	58
<b>Preparing for starting operation</b>	
see Starting operation	
<b>Protection of the environment</b> .....	5

## Q

<b>Qualified specialist workshop</b> .....	8
--	---

## R

<b>Refuelling</b>	
AdBlue®/DEF .....	39
Fuels .....	37
<b>Requirements of the personnel</b> .....	20
<b>Rev counter</b> .....	28
<b>Roadside Assistance</b> .....	51
<b>Running the vehicle in</b> .....	36

## S

<b>Safety and emergency running program</b> .....	6
<b>Safety precautions</b> .....	19

**Service products**

AdBlue®/DEF .....	45
Coolant .....	43
DEF/AdBlue® .....	45
Diesel fuel .....	44
Disposal .....	42
Disposing of AdBlue®/DEF .....	47
Engine oil .....	42
Fuel additives .....	45
General notes .....	42
Purity of AdBlue®/DEF .....	47
Storing AdBlue®/DEF .....	46

**Specialist workshop** ..... 8**Starting**

see Starting (engine)

**Starting (engine)** ..... 25**Stopping and switching off the****engine** ..... 25**T****Technical data**

Dimensions .....	61
Filling capacities .....	63
Operating data .....	62
Weights .....	61

**Tightening torques** ..... 63**Transport** ..... 21**W****Warning and indicator lamps**

Electronics .....	29
Engine, general .....	17

**Warning buzzer** ..... 37**Weights** ..... 61**Winter diesel** ..... 45**Winter operation** ..... 39

### Engine without exhaust gas after-treatment system

The engines without an exhaust gas aftertreatment system described in the document comply with the "EU Stage IIIA" emissions level.

These are certified in accordance with directive "ECE-R 96 Chapter 5.2.1 for power bands H or I".

The term "EU Stage IIIA" was taken from EU Directive 97/68, is still used in general parlance and is used in this document.

"EU Stage IIIA" emissions level is certified without an associated exhaust gas aftertreatment unit. An exhaust muffler with a silencer is used instead of an exhaust gas aftertreatment unit.

This means that the exhaust muffler used is determined by the vehicle or device and is covered in the operating instructions provided by the vehicle/device manufacturer.

### Engine system

In these Operating Instructions, the term "engine system" refers to the combination of the engine and exhaust gas aftertreatment unit. The engine and the emission control system are parts that require certification. The engine system is certified as one unit with the engine and exhaust gas aftertreatment unit assembly with the AdBlue® treatment reactor and the AdBlue® supply system.

Engine systems with exhaust gas aftertreatment can comply with the following emission levels depending on the version:

- EU Stage IV
- US Tier 4
- Japan 2014 - Heisei 26
- Korea Tier 4

### Protection of the environment

#### 🌱 Environmental note

Daimler AG has a declared policy of comprehensive environmental protection.

The objectives are to use the natural resources which form the basis of our existence on this planet sparingly and in a manner which

takes the requirements of both nature and humanity into account.

You too can help to protect the environment by operating your vehicle in an environmentally responsible manner.

Information and notes on driving in an environmentally responsible and fuel-saving manner can be found in the "Operating notes" section (> page 37).

### Assembly equipment

These Operating Instructions describe all models and all standard and optional equipment available for your engine system at the time of publication of the Operating Instructions. Country-specific deviations are possible. Note that your engine system may not be fitted with all features described. This also applies to safety-relevant systems and functions. Therefore, the equipment on your engine system may differ from certain descriptions and illustrations.

All of the components in your engine system are listed in the data card of your engine system. Data card (> page 60).

Please contact any MTU or MTU-authorized Mercedes-Benz Service Centre if you have any questions about equipment and operation (see addresses in the publication details on the inside of the back cover).

### Genuine Mercedes-Benz parts

#### 🌱 Environmental note

Daimler AG also supplies reconditioned assemblies and parts which are of the same quality as new parts. For these, the same warranty applies as for new parts.

If you use parts which have not been approved by Mercedes-Benz, the operational safety of the engine system may be jeopardised. This could lead to malfunctions in safety-relevant systems. Use only genuine Mercedes-Benz parts or parts of equal quality. Only use parts that have been approved for your engine type.

Mercedes-Benz checks genuine Mercedes-Benz parts for:

- reliability
- safety
- suitability

Despite ongoing market research, Mercedes-Benz is unable to assess other parts. Mercedes-Benz therefore accepts no responsibility for the use of such parts in Mercedes-Benz vehicles, even if they have been officially approved or independently approved by a testing centre.

In Germany, certain parts are only officially approved for installation or modification if they comply with legal requirements. This also applies to some other countries. All genuine Mercedes-Benz parts meet the approval requirements. The use of non-approved parts may invalidate the vehicle's general operating permit.

This is the case if:

- they result in a change to the vehicle type from that for which the vehicle's general operating permit was granted
- they pose a possible risk for road users
- they adversely affect the emission or noise levels

You can find more information on recommended conversion parts and accessories, as well as permitted technical modifications at any MTU or MTU-authorized Mercedes-Benz Service Centre (▷ page 8).

Always specify the assembly system ID number (AGS ID), the engine number and the number of the exhaust gas aftertreatment unit when ordering genuine Mercedes-Benz parts. You can find the engine number on the identification plate of your engine. You can find the number of the exhaust gas aftertreatment unit on the identification plate of the exhaust gas aftertreatment control module (ACM) (▷ page 60). You can also find the two numbers on the data card (▷ page 60).

The exhaust gas aftertreatment unit and the exhaust gas aftertreatment control unit (ACM) are not used for emissions certificate EU Stage IIIA.

## Modifying the engine output

**!** Increased power could:

- change emission levels
- cause malfunctions
- lead to consequential damage

The operating safety of the engine cannot be guaranteed in all situations.

Any tampering with the engine management system in order to increase the engine power output will lead to a loss of warranty entitlements.

## Safety/emergency running program

The engine is equipped with an electronic engine management system that monitors not only the engine and the exhaust gas aftertreatment unit (not for EU Stage IIIA) but also itself (self-diagnosis).

If the electronic control system detects a malfunction, one of the following measures is automatically implemented after an appraisal of the malfunction:

- faults during operation are indicated by the corresponding warning lamp (▷ page 29).
- in conjunction with the electronic engine management system, fault codes with additional information can be shown on a display.
- the system switches to a suitable backup function for the continued, albeit restricted, operation of the engine. This includes torque and engine speed limitation, for example, as well as road speed limitation or constant emergency running speed.

## Correct use

The engine system may only be installed as contractually specified.

The manufacturer of the end product is responsible for the correct installation of the engine and the exhaust gas aftertreatment system (not for EU Stage IIIA) in the overall system.

The engine and the exhaust gas aftertreatment system may not be modified. In the event of modification, Mercedes-Benz and MTU do not



accept responsibility for any damage arising as a result.

Correct use of the engine system also requires adherence to the instructions in these Operating Instructions. This also requires compliance with the maintenance intervals and the professional execution of maintenance work. Please observe the Workshop Information System (WIS) (> page 8).

### Implied warranty

A well-developed network of MTU or MTU-authorized Mercedes-Benz Service Centres is available to carry out maintenance work.

These MTU or MTU-authorized Mercedes-Benz Service Centres:

- have special equipment and tools as well as specialists who receive continuous training
- guarantee that your engine system is repaired and maintained thoroughly and expertly
- carry out all repairs related to implied warranty
- carry out all maintenance work expertly
- confirm in the Maintenance Booklet that the maintenance work has been carried out at the required time
- handle implied warranty claims that are admissible according to the sales contract

Please follow the instructions in this Service Booklet, even if you hand the vehicle/device over to a third party for use or care.

If the specified service/maintenance work is not carried out, the decision as to whether a warranty claim can be accepted or not can be made only after the manufacturer has inspected the claim.

During the implied warranty period, have the prescribed maintenance service for your engine system carried out as follows:

- regularly
- punctually
- at a qualified specialist workshop which has the necessary specialist knowledge and tools to carry out the work required

Confirmation that all service/maintenance work has been carried out at a qualified specialist workshop will be entered in this Maintenance Booklet.

If there are legal requirements on emission control, please note that:

- maintenance on the engines must be carried out according to specific regulations and using special measuring devices
- it is prohibited to modify or tamper with components relevant to emissions

Confirmation that all service/maintenance work has been carried out at a qualified specialist workshop will be entered in this Maintenance Booklet.

Maintenance work does not include repair work. Repair work will be invoiced separately.

You can obtain further information on the maintenance of your engine system from any MTU or MTU-authorized Mercedes-Benz Service Centre.

### Stored data

Several of the electronic components in your engine system contain data memories.

These data memories temporarily or permanently store technical information about:

- the engine system state
- events
- malfunctions

In general, this technical information documents the state of a component, a module, a system or the surroundings.

This includes, for example:

- operating conditions of system components, e.g. fluid levels
- the vehicle/device status messages and those of its individual components, e.g. speed, deceleration in movement, accelerator position
- malfunctions and defects in important system components
- the vehicle/device reactions and operating statuses in special driving situations
- ambient conditions, e.g. outside temperature

This data is exclusively technical in nature and can be used to:

- assist in the detection and rectification of faults and defects
- analyse vehicle functions, e.g. after an accident

The data cannot be used to trace the vehicle's movements.

When you use one of the available services, technical information may be read from the event data memory and fault data memory.

Services include, for example:

- repair services
- service processes
- implied warranty and guarantee cases
- quality assurance

The information is read out by employees of the service network (including manufacturers) using special diagnostic testers. Further information is available there if required.

After a fault has been rectified, the information is deleted from the fault memory or is continually overwritten.

### Qualified specialist workshop

A qualified specialist workshop has the necessary specialist knowledge, tools and qualifications to carry out the work required on the engine to a professional standard. This is particularly applicable to work relevant to safety.

Observe the notes in the Maintenance Booklet.

Always have the following maintenance work carried out at a qualified specialist workshop:

- work relevant to safety
- service and maintenance work
- repair work
- modifications as well as installations and conversions
- work on electronic components

Please consult an MTU or MTU-authorized Mercedes-Benz partner.

### Further applicable documents

These operating instructions describe all models and all standard and optional equipment available for your engine system within the scope of delivery of Daimler AG. The installation of the engine system into the vehicle/device may require additional operating instructions adapted to the vehicle/device and the appropriate use thereof. These additional operating instructions will be provided by the vehicle/

device manufacturer (manufacturer of the end product). The additional operating instructions will describe, in particular, the functions specific to the installation and operation, the use of such functions as well as warning and control mechanisms.

To use the engine correctly, you also require the Maintenance Booklet.

For US-certified off-highway engines you also require the "Emission Warranty" supplement.

Always keep these documents together with the engine, vehicle or device. These documents should be passed on to the new owner if you sell the engine, vehicle or device.

When carrying out maintenance work, you require access to the Workshop Information System (WIS) via the Internet. This access is subject to a fee.

Current information on the system and prices can be found at this web address: <http://service-parts.mercedes-benz.com>. Click on "EPC, WIS/ASRA" in the "Service and parts information" tab and then on "WIS".

You can log in by clicking on "Register" on the right-hand side.

## General information

The engine is a four-stroke, water-cooled diesel engine with direct injection.

The engine is equipped with a common rail diesel injection system, cooled and regulated exhaust gas recirculation and exhaust gas turbocharging with charge-air pressure control.

Depending on the engine output, engine turbocharging is either by means of single-stage exhaust turbocharging or two stage exhaust gas turbocharging with two sequential exhaust gas turbochargers of differing dimensions.

The valve gear has two camshafts at the top, which are driven via a gearwheel drive.

The engine features a single-piece cylinder head. In the cylinder head there are two inlet valves and two exhaust valves per cylinder. The valves are arranged symmetrically. The symmetrical valve arrangement is optimal for combustion.

The exhaust gas aftertreatment unit is characterised by the following technologies (not for EU Stage IIIA):

- selective catalytic reduction (SCR) with ammonia slip catalytic converter
- diesel oxidation catalytic converter (DOC)

The engine brake is a decompression brake. It has a controlled exhaust valve which gives it high braking power. The engine brake is controllable in steps or modulated.

## Engine overview

## At a glance

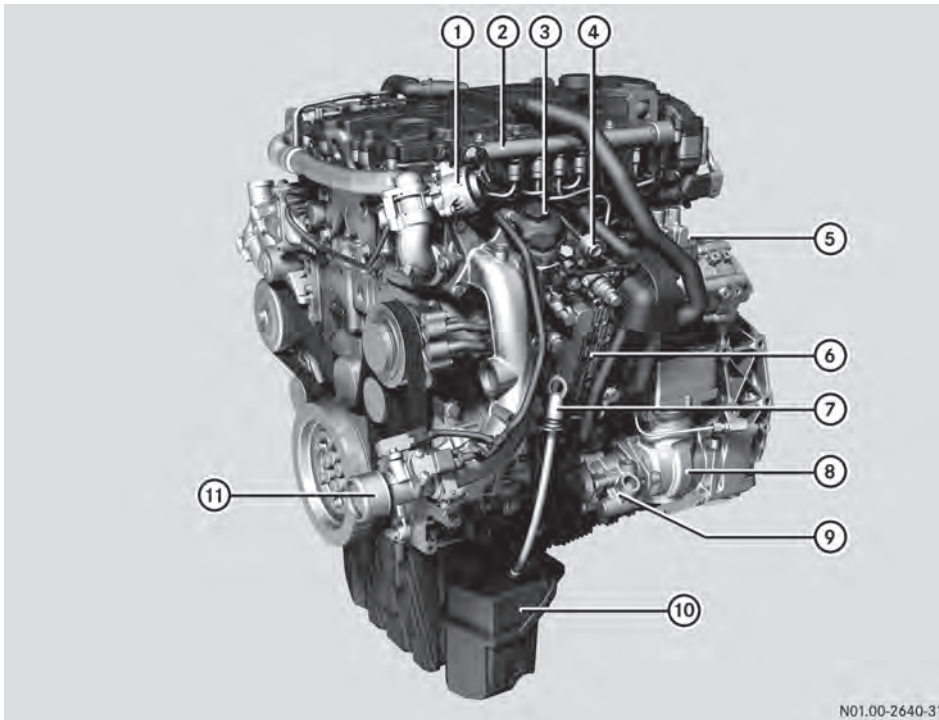

N01.00-2640-31

Engine overview: 4R 1000 with single-stage charging

- ① Exhaust gas recirculation positioner
- ② Rail
- ③ Fuel filter
- ④ External engine start/engine stop button
- ⑤ High-pressure fuel pump
- ⑥ Engine management control module (MCM)
- ⑦ Dipstick
- ⑧ Air compressor
- ⑨ Power-steering pump
- ⑩ Oil pan
- ⑪ Charge-air pipe (cold)

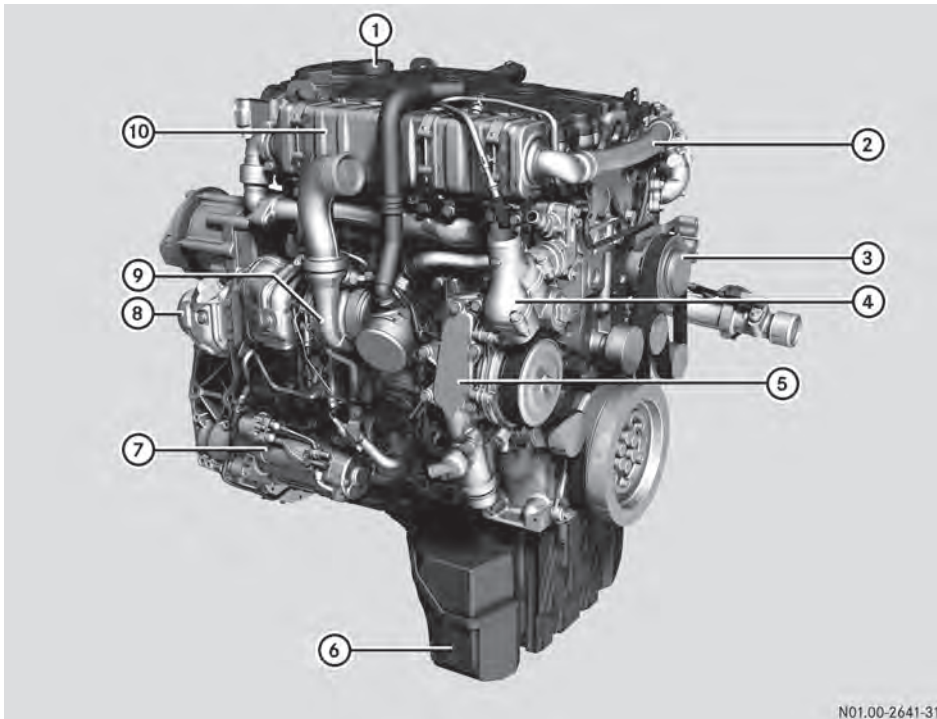

N01.00-2641-31

Engine overview: 4R 1000 with single-stage charging

- ① Crankcase ventilation system
- ② Exhaust gas recirculation pipe (cold)
- ③ Refrigerant compressor
- ④ Coolant thermostat
- ⑤ Combined oil filter/oil cooler module with coolant pump
- ⑥ Oil pan
- ⑦ Starter motor
- ⑧ Exhaust pipe to exhaust gas aftertreatment unit
- ⑨ Exhaust gas turbocharger
- ⑩ Exhaust gas recirculation cooler

## At a glance

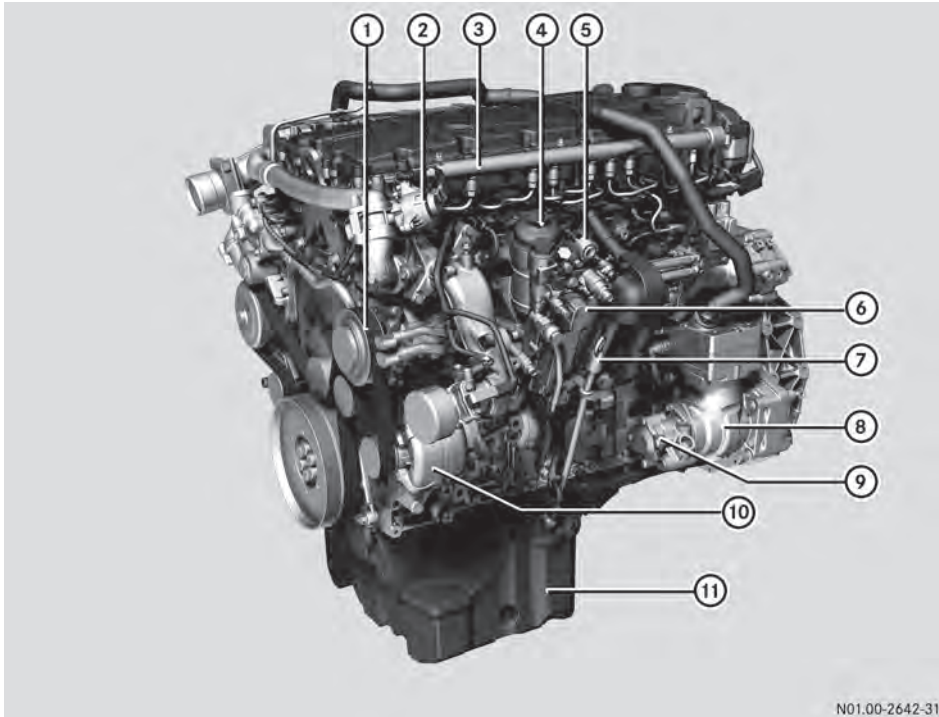

N01.00-2642-31

Engine overview: 6R 1000 with two-stage charging

- ① Refrigerant compressor
- ② Exhaust gas recirculation positioner
- ③ Rail
- ④ Fuel filter
- ⑤ External engine start/engine stop button
- ⑥ Engine management control module (MCM)
- ⑦ Dipstick
- ⑧ Air compressor
- ⑨ Power-steering pump
- ⑩ Alternator
- ⑪ Oil pan

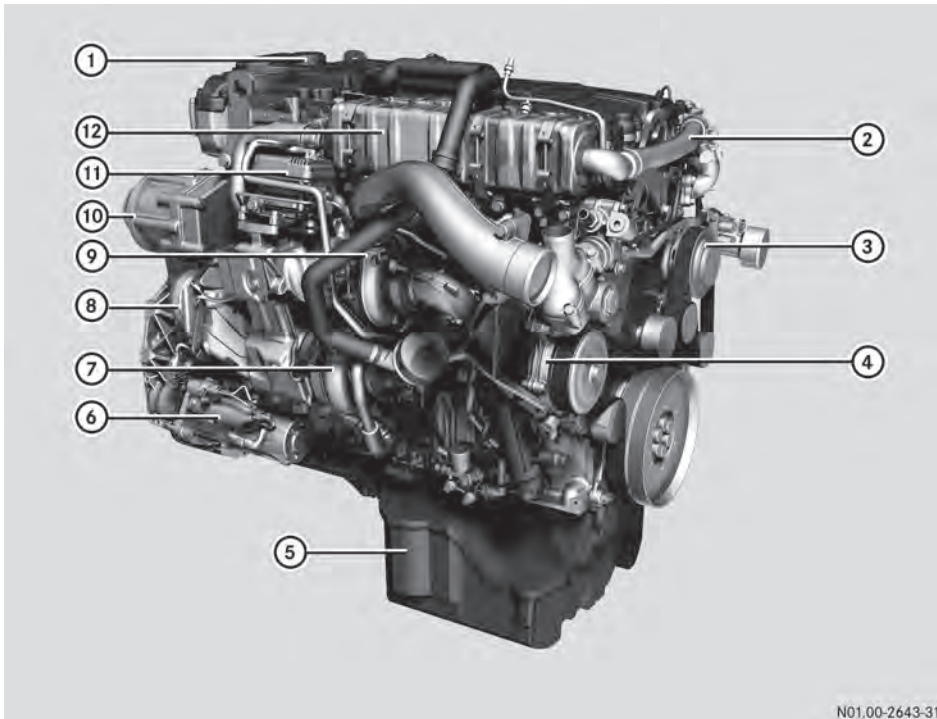

N01.00-2643-31

At a glance

Engine overview: 6R 1000 with two-stage charging

- ① Crankcase ventilation system
- ② Exhaust gas recirculation pipe (cold)
- ③ Refrigerant compressor
- ④ Combined oil filter/oil cooler module with coolant pump
- ⑤ Oil pan
- ⑥ Starter motor
- ⑦ Low pressure exhaust gas turbocharger
- ⑧ Exhaust pipe to exhaust gas aftertreatment unit
- ⑨ High pressure exhaust gas turbocharger
- ⑩ Power take-off (PTO)
- ⑪ Boost pressure positioner
- ⑫ Exhaust gas recirculation cooler

## Exhaust gas aftertreatment overview

At a glance

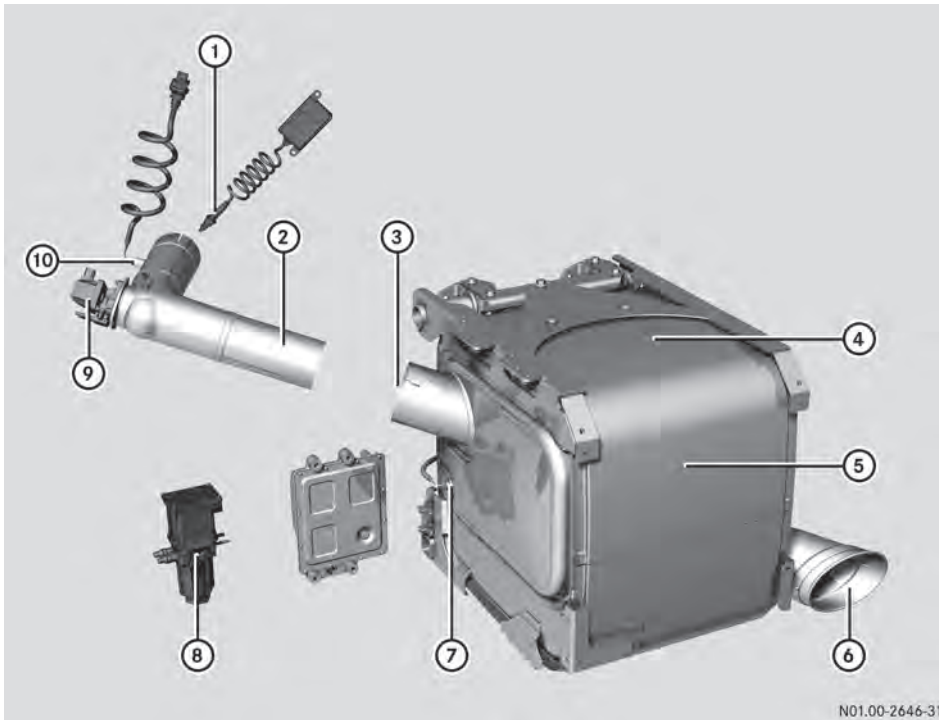

N01.00-2646-31

Exhaust gas aftertreatment unit (not for EU Stage IIIA)

- ① NOx sensor on exhaust gas aftertreatment unit inlet
- ② AdBlue® mixing tube
- ③ Exhaust gas inlet from AdBlue® mixing tube
- ④ Position of exhaust gas aftertreatment identification plate
- ⑤ Exhaust gas aftertreatment box
- ⑥ Exhaust gas outlet
- ⑦ Exhaust gas temperature sensor upstream of the SCR catalytic converter
- ⑧ Pump module
- ⑨ AdBlue® or DEF metering unit
- ⑩ Exhaust gas temperature sensor upstream of the AdBlue® metering unit



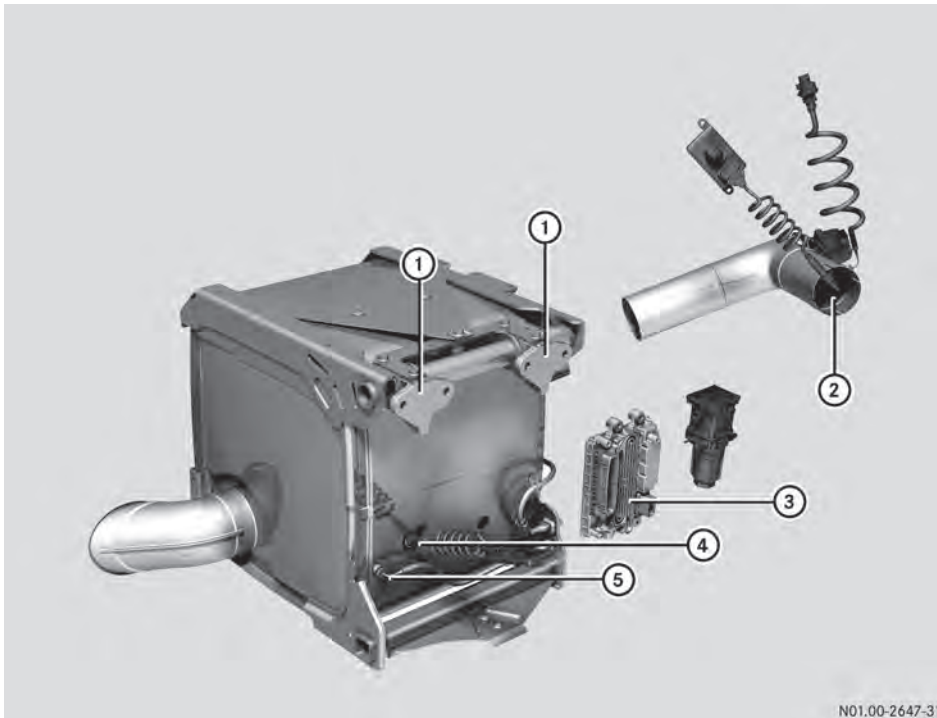

Exhaust gas aftertreatment unit (not for EU Stage IIIA)

- ① Mounting brackets
- ② Exhaust gas inlet from engine
- ③ Exhaust gas aftertreatment control unit (ACM)
- ④ NOx sensor on exhaust gas aftertreatment unit outlet
- ⑤ Exhaust gas temperature sensor downstream of the SCR catalytic converter

## Electronic engine management

The engine system is equipped with an electronic engine management system which comprises the following control units:

- Engine management control module (MCM)
- Drive control system unit (CPC)
- Exhaust gas aftertreatment control module (ACM) (not for EU Stage IIIA)

The control units are connected in an electronic network. Data is exchanged via CAN (Controller Area Network).

In addition to the engine, the exhaust gas aftertreatment and the connection to the vehicle/device, the electronic engine management system also monitors itself.

Depending on the malfunctions or failures which occur, warning and indicator lamps are activated (▷ page 17). The malfunction is stored in the fault memory and if necessary a safety and emergency mode is automatically selected (▷ page 28). If the electronic engine management control detects a fault, the fault code is stored in the control units. It can then be read by a qualified specialist workshop (▷ page 8) using a diagnostic tester.

### Engine management control module (MCM)

The engine management control module (MCM) is located on the side of the engine. It acts as an

interface between the electric and electronic components on the engine and the drive control system unit (CPC) on the vehicle.

The engine management control module (MCM) has many functions:

- Injection control of the common rail diesel injection system
 

The engine management control module (MCM) calculates the optimum start and quantity of injection, taking the torque demand from the drive control system unit (CPC) into account.

All of the data required for this, e.g. power output or data which serves to protect the engine, is stored in the engine management control module (MCM).
- Regulation of exhaust gas recirculation (EGR)
 

The ratio between the mass of recirculated exhaust gas and the fresh air mass is precisely regulated over the entire engine speed range.
- Charge-air pressure control
- Control of the engine brake
 

The engine management control module (MCM) controls the engine brake as required by the drive control system unit (CPC).
- Fan regulation
 

In optional fan regulation, the solenoid valve on the fan clutch is activated according to coolant temperature.
- Instrument cluster display
 

For the displays in the instrument cluster, the engine management control module (MCM) detects the following:

  - Engine oil level
  - Engine oil temperature
  - Oil pressure
  - Coolant temperature
  - Engine speed

#### Drive control system unit (CPC)

The drive control system unit (CPC) is installed in a protected location in the vehicle/device by the vehicle/device manufacturer. It acts as an interface between the electric and electronic components on the vehicle/device and the engine management control module (MCM) on the engine.

The drive control system unit (CPC) has many functions:

- Calculation of torque demand
 

The drive control system unit (CPC) registers the driver's requirements. For example, the position of the accelerator is detected by the drive control system unit (CPC). A torque requirement is calculated from that and sent to the engine management control module (MCM) via the CAN connection.

In doing so, information and limitations from optionally connected control units such as the gearbox control, retarder control, ABS and ASR are taken into account.
- Output of displays and indicator signals which are displayed in the instrument cluster.
- Monitoring of coolant level, charge current and air filter, for example
- Legal speed limitation
- Evaluation of start request
 

The engine starting process is initiated once a corresponding start request is present (ignition lock or external engine start/engine stop button).

#### Exhaust gas aftertreatment control module (ACM) (not for EU Stage IIIA)

The exhaust gas aftertreatment control module (ACM) is installed in a protected location in the vehicle/device by the vehicle/device manufacturer. It regulates and controls the exhaust gas aftertreatment system.

Functions of the exhaust gas aftertreatment control module (ACM):

- Evaluation of sensor signals
 

The sensor signals of the directly connected sensors are evaluated. Data provided via the CAN by the engine management control module (MCM) and the control units for the NOx sensors is also evaluated.
- AdBlue®/DEF injection
 

Calculation of the required amount of AdBlue®/DEF and supply of AdBlue®/DEF by actuation of the SCR delivery pump.

Injection by actuation of the AdBlue®/DEF metering unit.

### BlueTec® exhaust gas aftertreatment (not for EU Stage IIIA)

The exhaust gas aftertreatment system is activated immediately after the engine is started and remains activated during engine operation. It ensures that the pollutant emissions in the exhaust gas are reduced to the limits stipulated in the emissions standard.

Exhaust gas treatment is carried out by:

- selective catalytic reduction (SCR) with ammonia slip catalytic converter
- diesel oxidation catalytic converter (DOC)

In order to ensure correct operation of the exhaust gas aftertreatment system, only operate the engine/vehicle with the AdBlue® reducing agent. AdBlue®/DEF is not refilled as part of the maintenance work. You should therefore top up the AdBlue®/DEF tank regularly.

Operating the vehicle or device without AdBlue®/DEF or with another medium that has not been approved by Mercedes-Benz or MTU invalidates the engine's operating permit or certification.

### Exhaust gas recirculation

Exhaust gas recirculation (EGR) serves primarily to reduce the amount of nitrogen oxide prior to exhaust gas aftertreatment. This serves to comply with emissions limits.

Exhaust gas is added to the fresh air being drawn in or charged so that the concentration of oxygen in the combustion mixture is reduced. Combustion deteriorates if the concentration of exhaust gas in the combustion mixture is too high.

The emission of soot particles, carbon monoxide (CO) and hydrocarbons (HC) increases.

Conversely, the emission of nitrogen oxides (NO<sub>x</sub>) would increase if the concentration of fresh or charged air were too high.

### Warning and indicator lamps

#### Important safety notes







If you ignore warning and indicator lamps, you will not be able to recognise failures and malfunctions in components or systems. The driving and braking characteristics may change and the road and operating safety of your vehicle or equipment may be restricted. Have the affected system checked and repaired at a qualified specialist workshop. Always observe the warning and indicator lamps and follow the corresponding corrective actions (> page 29).

#### Overview

The indicator and warning lamp display is designed for the specific vehicle or equipment. Observe the information contained in the operating instructions of the vehicle or device. The symbols listed below are examples only and their appearance may differ in the vehicle or on the equipment.











In the event of a fault or warning, a warning lamp or indicator lamp lights up automatically. Depending on the priority of the fault or warning, the warning and indicator lamps light up in different combinations.

The following warning and indicator lamps may be available on the instrument panel:

Indicator lamp	Description
 red	Engine stop
	Engine system malfunction
 <sup>1</sup>	Emissions-relevant malfunction of the exhaust gas aftertreatment system or AdBlue®/DEF supply
 LIMIT <sup>1</sup> (lit constantly)	Torque operating restriction
 LIMIT <sup>1</sup> (flashing)	Torque and engine speed operating restriction
	Charge current

<sup>1</sup> Not for EU Stage IIIA

## At a glance

Indicator lamp	Description
 <sup>1</sup> (optional)	AdBlue <sup>®</sup> /DEF reserve level
 (optional)	Oil pressure too low (engine)
 (lit constantly)	Engine oil level low
 (flashing)	Engine oil level too low
 (optional)	Coolant level too low
 (optional)	Coolant temperature too high
 (optional)	Continuous brake active
 (optional)	Cruise control
 (optional)	Speed limiter
 (optional)	Power take-off engaged

<sup>1</sup> Not for EU Stage IIIA

## Operating safety

### WARNING

If you do not have the prescribed service/maintenance work or necessary repairs carried out, this could result in malfunctions or system failures. There is a risk of an accident. Always have the prescribed service/maintenance work as well as necessary repairs carried out at a qualified specialist workshop.

The operating safety of an engine system depends on its professional installation in the overall system (e.g. the vehicle or working machinery). As the operator of the engine, you also affect its safe operation.

Through compliance with the prescribed maintenance intervals, you fulfil part of the requirements for safe operation of the engine.

However, safe operation of the engine also depends upon its proper use and care. This includes, for example, regularly checking the oil level.

## Safety measures

Damage to the engine can also lead to personal injury. In order to avoid engine damage, the following safety precautions must be adhered to.

- Only start the engine when the batteries are firmly attached.
- Do not disconnect the batteries when the engine is running.
- Do not use a rapid charger to start the engine.
- Only perform the jump-starting procedure with separate batteries.
- Note, the battery terminals must be disconnected when rapid charging the batteries.
- Observe the operating instructions of the rapid battery charger.
- Please note that the "+" and "-" terminals on the batteries must be disconnected when carrying out electric welding work.
- The control unit connectors may only be connected/disconnected when the electrical system is switched off.

- Incorrect control unit-power supply polarity (e.g. by connecting up the batteries incorrectly) can cause irreparable damage to the control units.
- Tighten diesel injection system connections to the prescribed tightening torque.
- When drying paintwork, do not exceed a temperature of 80 °C (e.g. in the drying oven).
- Only use the appropriate testing probes when taking measurements from electrical connectors (e.g. a Mercedes-Benz connection set). Telephones and two-way radio devices that are not connected to an external aerial can cause malfunctions in the electronics and thus endanger the operating safety of the engine.

## Warning stickers

If you remove any warning stickers, you or others could fail to recognise certain dangers.

Various warning stickers are attached to the engine system. Their purpose is to make you and others aware of various risks.

## Notes on electronic systems

### Important safety notes

#### WARNING

Modifications to electronic components, their software as well as wiring could affect their function and/or the operation of other networked components. This could in particular also be the case for systems relevant to safety. They might not function properly anymore and/or jeopardise the operational safety of the vehicle. There is an increased risk of an accident and injury.

Do not attempt to modify the wiring as well as electronic components or their software. Always have work on electrical and electronic components carried out at a qualified specialist workshop.

The general operating permit for your vehicle/equipment could be rendered invalid if you carry

out modifications to electronic components, their software or their wiring.

### Electromagnetic compatibility

The electromagnetic compatibility of the engine system's components has been checked and certified according to the currently valid version of Directive ECE-R 10.

### Diagnostics connection

The diagnostics connection is used for connecting diagnostic equipment at a qualified specialist workshop.

#### WARNING

If you connect equipment to a diagnostics connection in the vehicle, it may affect the operation of vehicle systems. As a result, the operating safety of the vehicle could be affected. There is a risk of an accident.

Only connect equipment to a diagnostics connection in the vehicle, which is approved for your vehicle by Mercedes-Benz.

If the engine is switched off and devices connected to the diagnostics connection are being used, the starter battery can become discharged.

Connecting devices to the diagnostics connection can, for example, cause the emissions monitoring information to be reset. As a result, there is a possibility that the vehicle/equipment will not fulfil the requirements of the next legally prescribed emissions test.

### Staff qualifications

#### WARNING

If you do not have the prescribed service/maintenance work or necessary repairs carried out, this could result in malfunctions or system failures. There is a risk of an accident.

Always have the prescribed service/maintenance work as well as necessary repairs carried out at a qualified specialist workshop.

The engine should only be operated, maintained and repaired by trained personnel who have been briefed and authorised by the operator. The prescribed minimum legal age for personnel carrying out maintenance and repair work must be observed.

-  Further measures may be required for personnel, depending on national regulations. Comply with the relevant applicable regulations in your country.

### Organisational measures

The operator must determine the responsibilities for operation, maintenance and repairs. Give the Operating Instructions and the Maintenance Booklet to the personnel that are charged with operating or carrying out work on the engine.

Instruct personnel on how to operate the engine using the Operating Instructions. When doing so, put special emphasis on safety-relevant information. This is particularly important for personnel that only work occasionally on the engine.

Always keep the Operating Instructions and the Maintenance Booklet readily accessible, in the area of engine operation.

In addition to the Operating Instructions, other general, country-specific, legal and other binding regulations on accident prevention and environmental protection must be adhered to.

Please also observe the information in the additional operating instructions. These will be provided by the device/vehicle manufacturer.

## Transport

### WARNING

If you do not lift the engine as described, the lugs intended for the purpose may be torn out or snap. This may be the case especially if the maximum permissible lug load is exceeded. The engine could then drop uncontrolled, causing serious or even fatal injury.

Always make sure that:

- the engine is only lifted at the intended lifting points/lifting lugs.
- the engine is only lifted and transported in the fitting position.
- ropes/chains are always routed vertically.
- only parts which are typically in the original scope of delivery are attached to the engine.

### WARNING

If you lift the engine at unsuitable points and/or using unsuitable lifting gear, it may:

- work loose and fall off
- swing uncontrollably as a result of a change in the centre of gravity.

There is a risk of injury.

Lift the engine only at the lifting points provided using suitable lifting gear. Make sure that there is nobody in the danger zone when raising and lowering the engine.

**!** The engines are by default delivered filled with oil. If the engine is transported at an angle or on its side, oil could leak out. Only transport the engine in the installation position.

**!** Do not tread on the engine or the exhaust gas aftertreatment unit (not for EU Stage IIIA). They may otherwise become damaged.

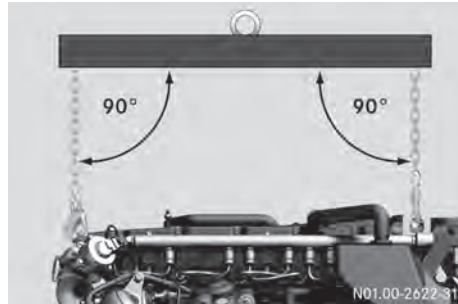

Example: using a cross member

The engine may only be lifted using a cross member with the chain/rope at 90° relative to the horizontal engine.

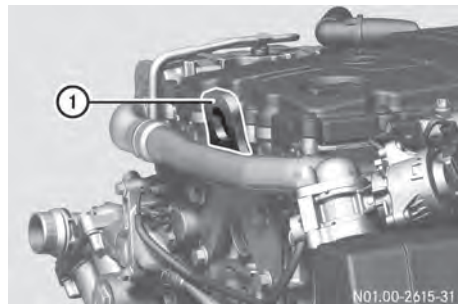

① Example: belt-side lifting point

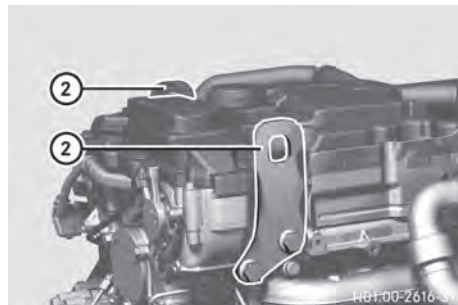

② Example: flywheel-side lifting point

## Installation

The engine system may only be installed as contractually specified.

Observe the sections "Correct use" (> page 6) and "Modifying the engine output" (> page 6).

Daimler AG provides the vehicle manufacturer with comprehensive material, e.g. the installa-

tion guideline, for initial installation. The vehicle manufacturer must take this into account. If the engine is fitted after repair work, for example, the information in the Workshop Information System (WIS) must be taken into account (▷ page 8).

Observe the sections "Qualified specialist workshop" (▷ page 8) and "Further applicable documents" (▷ page 8).

Please consult an MTU or MTU-authorized Mercedes-Benz Service Centre if you have any questions.



## Preparation for operation

### Engine with initial operation oil from the factory

The engine is filled at the factory with an initial operation oil.

These high-quality engine oils are beneficial to the running-in process. They also allow you to make the first oil change in accordance with the applicable oil change intervals. This eliminates the need for special break-in oils and the additional oil change otherwise required.

### Checking the engine oil level

The engine is equipped with an electronic oil level detection system.

If the engine is also equipped with a dipstick, this is subsidiary to the electronic oil level measurement system.

### Electronic oil level measurement – system description

The engine oil level sensor is installed in the oil pan for oil level measurement. The electrical signals are detected in the engine management control module (MCM) and transmitted to the drive control system control unit (CPC).

Output can be displayed by indicator lamps or on a matrix display when the engine is not running and the ignition is switched on.

The engine oil level is not displayed while driving.

### Checking the oil level electronically

**!** Do not add too much oil. If you add too much oil, the engine or the exhaust aftertreatment unit could be damaged. Drain or siphon off any excess oil.

Check the engine oil level on a regular basis, e.g. daily before driving or each time you refuel.

Please also observe the information in the Operating Instructions provided by the vehicle/device manufacturer.

- ▶ Park the vehicle/device on a level surface.
- ▶ Apply the parking brake.
- ▶ Switch off the engine

- ▶ Switch the ignition lock to the drive position.
- ▶ Wait for at least five minutes after switching off the engine.

**i** The current oil level information can only be called up when the vehicle is stationary and at least 5 minutes after the engine was switched off. Then switch on the ignition and wait for the lamp failure indicator.

**!** To measure the oil level, the vehicle or device must be on a level surface. If the oil level is measured while the vehicle is on a slope, false readings will be displayed

If the oil level is low, the  indicator lamp lights up

If the oil level is too low and the engine should not be started, the  indicator lamp flashes

- ▶ If necessary, use filler neck ① to top up the oil.

Only use engine oil which has been approved for the engine and which meets the specified SAE classification (> page 42).

### Oil level messages via indicator lamp

If the oil level is low the  indicator lamp lights up. The oil level is low. Add oil. Use the dipstick to determine the quantity to be added.

**i** The missing amount should be refilled immediately. If the engine oil level is too low, the  indicator lamp flashes and the warning buzzer sounds. The oil level is **too** low; do not start the engine and refill oil immediately. Use the dipstick to determine the quantity to be added.

**!** The oil level must be corrected immediately; there is a risk of engine failure.

### Oil level messages via matrix display

The display of oil level messages is determined by the vehicle or device manufacturer. Please observe the information in the operating instructions provided by the vehicle/device manufacturer.

If the engine oil level is low, refill the quantity of missing oil shown in the display.

If the engine oil level is **too** low, do not start the engine and refill the quantity of missing oil shown in the display.

**!** The oil level must be corrected immediately; there is a risk of engine failure.

### Checking the oil level with the dipstick

**!** Do not add too much oil. If you add too much oil, the engine or the exhaust aftertreatment unit could be damaged. Drain or siphon off any excess oil.

Check the engine oil level on a regular basis, e.g. before each journey or each time you refuel.

- ▶ Park the vehicle/device on a level surface.
- ▶ Apply the parking brake.
- ▶ Switch off the engine.
- ▶ Wait for approximately 5 minutes.

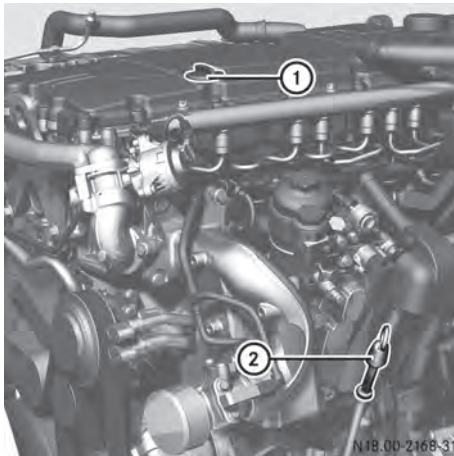

- ▶ Check the engine oil level with dipstick ②. The oil level should be between the upper and lower marks on dipstick ②.
- ▶ If necessary, use filler neck ① to top up the oil.

Only use engine oil which has been approved for the engine and which meets the specified SAE classification (▷ page 42).

### Checking the coolant level

- ▶ Check the coolant level as stated in the vehicle's/device's Operating Instructions.
- ▶ Fill the cooling system if necessary. Only use coolant that has been approved for the engine (▷ page 43).

### Checking the fuel level

For checking the fuel level on the fuel gauge, see the vehicle Owner's Manual. Refuel if necessary (▷ page 44).

### Checking the water level in the fuel prefilter on the chassis frame

#### ⓘ Environmental note

Dispose of the water-fuel mixture in an environmentally responsible manner.

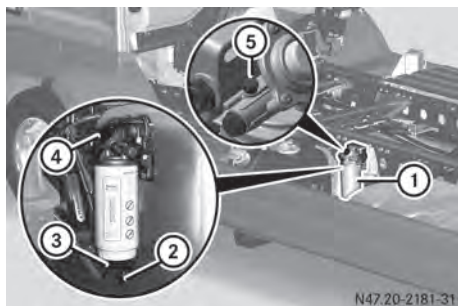

Example: fuel prefilter on the chassis frame

	Function	Page
1	Fuel prefilter	
2	Drain plug	
3	Inspection window	
4	Manual fuel pump	
5	Bleed screw	

If water has collected in inspection window ③, drain fuel prefilter ① on the chassis frame.

Drain fuel prefilter ① on the chassis frame when necessary; if there is a danger of frost, do this on a regular basis.

Draining the fuel prefilter on the chassis frame

- Place a collecting pan under drain plug ②.
- Turn drain plug ② open.
- Press manual fuel pump ④ and collect the fuel/water mixture.
- Turn drain plug ② closed.

### Check the AdBlue®/DEF level (not for EU Stage III3A)

For checking the AdBlue®/DEF supply on the AdBlue®/DEF gauge, see the vehicle Owner's Manual. Refuel if necessary (▷ page 39).

## Starting and stopping the engine

### Starting the engine

#### WARNING

Combustion engines emit poisonous exhaust gases such as carbon monoxide. Inhaling these exhaust gases leads to poisoning. There is a risk of fatal injury. Therefore never leave the engine running in enclosed spaces without sufficient ventilation.

**!** If the oil pressure in the engine is too low, a warning light lights up on the instrument panel. The warning buzzer also sounds.

The operating safety of the engine is jeopardised. Switch off the engine immediately.

**!** Do not pull away as soon as the engine starts. Let the engine run in neutral for a short time after starting, until there is sufficient engine oil pressure. Do not drive at high engine speeds when the engine is cold.

This will prevent excessive wear and possible engine failure.

Warm up the engine quickly by driving at moderate engine speeds. Depending on the outside temperature, the engine will reach its operating temperature after approximately 10 to 20 minutes (▷ page 62).

You can utilise the full engine power output once the engine has reached its normal operating temperature.

The indicator and warning lamp display is designed for the specific vehicle or equipment. Please also observe the information in the additional operating instructions. These supplemental operating instructions are provided by the vehicle/device manufacturer.

For additional safety, the electronic engine management system is equipped with a function that only allows the engine to be started when the transmission is in neutral (vehicle-specific/device-specific).

### Starting the engine with the key

**!** After starting the engine, let it run at engine idling speed until the oil pressure is displayed. If no oil pressure is displayed after approximately 10 seconds, switch off the engine.

Determine the cause. The operating safety of the engine is jeopardised.

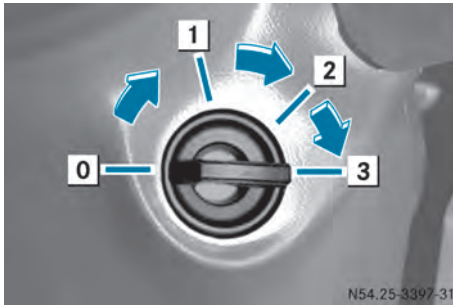

## Operation

Example: ignition lock

- 0 To insert/remove the vehicle key
  - 1 Steering wheel unlocked/radio position
  - 2 Drive position (ignition)
  - 3 Start position
- ▶ Secure the vehicle/device against rolling away.
  - ▶ Deactivate power take-off.
  - ▶ Shift into neutral.
  - ▶ **To start the engine:** turn the key in the ignition lock to drive position **2**.
  - ▶ Turn the key to start position **3** in the ignition lock. Do not depress the accelerator pedal whilst doing so.
  - ▶ When the engine has started, release the key. The idling speed is controlled automatically.
  - ▶ **i** The engine idling speed is raised at very low outside temperatures.
  - ▶ If the engine does not start immediately: interrupt the starting procedure after no more than 30 seconds.
  - ▶ Turn the key in the ignition lock back to the stop at key position **0**.
  - ▶ Repeat the starting procedure after a waiting period of approximately 1 minute.
  - ▶ If the engine fails to start: rectify the cause of the poor starting characteristics (▷ page 55).
  - ▶ Observe the oil pressure gauge immediately after having started the engine.

## Starting the engine with the external engine start/engine stop button

- ▶ **To start the engine with the external engine start/engine stop button:** (▷ page 51).

## Stopping the engine

### ⚠ WARNING

When switching off the equipment or parking the vehicle, make sure that the exhaust system does not come into contact with combustible objects, e.g. dry leaves, grass or other highly flammable materials.

### ⚠ WARNING

If you switch off the ignition while the vehicle is in motion, safety-relevant functions are restricted or not available. This can affect the power steering function and the brake boosting effect, for example. You will then require considerably more force to steer and brake. There is a risk of an accident.

Do not switch off the ignition while the vehicle is in motion.

- ▶ **!** Stop the engine immediately, paying attention to the road and traffic conditions if:
  - the oil pressure falls or fluctuates significantly.
  - the power output or engine speed decreases and the position of the position sensor (accelerator) remains constant.
  - heavy smoke is emitted from the exhaust.
  - the coolant or engine oil temperature rises steeply.
  - abnormal noises suddenly come from the engine or exhaust gas turbocharger.
- ▶ Park the vehicle/equipment.
- ▶ Secure the vehicle/device against rolling away.
- ▶ Shift the transmission into neutral/decouple the drive system.

Let the engine idle for approximately two minutes before switching off the engine if:

- the coolant temperature is very high (over 100 °C).
- the engine has been operated at full output.

► **To switch off the engine:** turn the vehicle key in the ignition lock back to the stop at position **0**.

**i** When you switch off the engine (not for EU Stage IIIA emissions certification) the system may continue to run for a short while. Depending on the installation position, operating state and ambient temperature, circulation of AdBlue®/DEF is necessary to ensure cooling. To do this the AdBlue®/DEF delivery pump is actuated during this period.

### Switching off the engine with the external engine start/engine stop button

► **Switch off the engine with the external engine start/engine stop button:** (> page 51).

### Switching the continuous brake on and off

#### WARNING

If you activate the continuous brake or shift to a lower gear on a slippery road surface in order to increase the engine's braking effect, the drive wheels may lose traction. There is an increased risk of skidding and an accident.

Do not activate the continuous brake and do not shift to a lower gear in order to increase the engine's braking effect on a slippery road surface.

The engine brake and retarder are used as a continuous brake.

You can utilise the engine's braking effect, particularly on long downhill gradients if you:

- activate the continuous brake
- shift to a lower gear in good time

Slowly depress the brake pedal if the engine's braking effect is insufficient when driving downhill.

Vehicles without a retarder are equipped with only two brake stages.

Operation of the continuous brake (see the vehicle/device operating instructions).

The  indicator lamp in the instrument cluster is lit when the continuous brake is active.

When ABS (Anti-lock Braking System) intervenes, the continuous brake is switched off. The  indicator lamp in the instrument cluster remains on.

### Engine brake

The effectiveness of the engine brake depends on the engine speed. A high engine speed results in more effective engine braking.

Note the effective engine braking range marked on the rev counter (> page 28).

The maximum permissible engine speed may be restricted, depending on the vehicle/device application.

Observe the information contained in the operating instructions of the vehicle or device.

At very low outside temperatures, the engine brake has limited or no effect after the engine has been started.

Operation of the engine brake (see the vehicle or device operating instructions).

### Retarder

Operation of the retarder; see the vehicle or device operating instructions.

### Idling speed

After the engine has been started, idling speed is regulated automatically. The engine idling speed may differ in certain operating conditions depending on the engine or on vehicles with power take-off.

You can set the idling speed to between approximately 600 and 800 rpm.

The engine idling speed is raised at very low outside temperatures.

You can set the speed to the working speed via the electronic engine management system. This makes it possible to drive auxiliary equipment such as pumps at their working speed. For set-

ting the working speed, see the vehicle operating instructions.

## Climate control

### Air-conditioning system

**!** Turn on the air-conditioning system at least once a month for approximately ten minutes. The refrigerant compressor may otherwise be damaged.

#### Environmental note

Only switch on the air-conditioning system when necessary. Fuel consumption increases when the air-conditioning system is switched on.

The air-conditioning system can only be operated when the engine is running. Operation of the air-conditioning system (see the vehicle's Operating Instructions).

## Operational monitoring

### Charge current

The charge current indicator lamp must go out after the engine has started.

If the  indicator lamp does not go off or lights up when the engine is running, switch off the engine. Searching for and eliminating the cause of the malfunction (> page 55).

### Electronic engine management

The indicator and warning lamps must go out after the engine has started.

If an indicator lamp or warning lamp does not go out, or if it lights up while the engine is running, there is a malfunction in the electronic engine management system.

Searching for and eliminating the cause of the malfunction (> page 55).

Each malfunction is stored in the system with its own fault code. Temporary faults are also stored.

Fault codes can be read by a qualified specialist workshop using a diagnostic tester (> page 6).

### Oil pressure

If the  indicator lamp does not go out or if it lights up when the engine is running, switch off the engine. Searching for and eliminating the cause of the malfunction (> page 55).

### Operating restrictions (not for EU Stage IIIA)

The electronic engine management system monitors:

- emissions-relevant malfunctions in the exhaust gas aftertreatment
- malfunctions in the electronic monitoring of the exhaust gas aftertreatment system
- consumption, level and quality of the AdBlue®/DEF reducing agent
- the efficiency of the catalytic converter in accordance with the permitted thresholds for nitric oxide emissions (NOx)

Operating restrictions in the form of torque reduction and thus output and speed limitation may occur.

### Emergency switch for overriding operating restrictions (not for EU Stage IIIA)

A detected emissions-related malfunction in the exhaust gas aftertreatment system or the AdBlue®/DEF supply can result in restricted operation (limitation of engine torque and engine speed).

In case of emergency a button can be pressed to override the operating restriction. This means that full engine power is available for a maximum of 30 minutes. This emergency function by operating the switch can be activated a maximum of three times.

When the final operating restriction (idling speed and 20% of torque) has been reached, the button is disabled.

## Displays

### Rev counter

**!** If you exceed the maximum permissible engine speed, the warning tone sounds.

You should not drive and change gear by the sound of the engine, but according to the engine speed shown in the rev counter.

Avoid driving in the red overrevving range. This could lead to engine damage.

The engine speed display is the responsibility of the vehicle manufacturer and is not necessarily supplied by Mercedes-Benz. Daimler AG recommends that the vehicle manufacturer uses a rev counter divided by:

- operational efficiency
- engine braking range
- engine overrevving range

General notes on the rev counter:

- Keep an eye on the rev counter while driving and stay within the economical operating range.

In some situations it may make sense to operate the engine outside the economical engine speed range, e.g. on uphill gradients or when overtaking.

- If you run the engine within the economical engine speed range, you achieve low fuel consumption and reduced wear.
- In engine braking mode, drive in the middle engine speed range. The highest engine braking effect will be achieved just before the red overrevving range.
- When driving downhill, make sure that the engine speed does not enter the overrevving range (marked red).
- Idling speed is set automatically depending on the coolant temperature.
- When the vehicle is stationary, the engine is running and the transmission is in neutral, the engine increases throttle only slowly.

### AdBlue®/DEF level (not for EU Stage IIIA)

The AdBlue®/DEF display is the responsibility of the vehicle manufacturer and is not necessarily supplied by Mercedes-Benz. Daimler AG recommends that the vehicle manufacturer uses an AdBlue®/DEF gauge and an AdBlue®/DEF indicator lamp for the AdBlue®/DEF reserve level .

The AdBlue®/DEF reducing agent is required for reduction of engine emissions.

The MOT approval/operating permit is invalidated if the vehicle is operated without AdBlue®/DEF. The legal consequence of this is that the vehicle may no longer be operated on public roads.

If the AdBlue®/DEF level has sunk to approximately 10%, a warning lamp for the AdBlue®/DEF reserve level lights up on the instrument panel. Top up the AdBlue®/DEF tank in good time (▷ page 39).

If the display is ignored and the AdBlue®/DEF level drops further, engine torque and engine speed may be reduced (▷ page 28).

The engine torque can be limited to a maximum of 20% across the whole engine speed range. The engine speed can be limited to idling speed.





## Warning and indicator lamps

### Warning and indicator lamps – causes/consequences and solutions





The display format for indicator and warning lights is vehicle-specific/device-specific. Please observe the information contained in the device/vehicle operating instructions. The symbols listed below are examples and may differ from those symbols displayed in the vehicle/device. Depending on the priority of the fault or warning, the warning and indicator lamps light up in different combinations.



If you ignore warning and indicator lamps, you will not be able to recognise failures and malfunctions in components or systems. Have the affected system checked and repaired at a qualified specialist workshop.

## Warning and indicator lamps

Problem	Possible causes/consequences and ► Solutions
The  indicator lamp lights up red.	<p>A serious fault in the engine system has been detected.</p> <p>► Immediately stop the vehicle/device while paying attention to the traffic conditions and contact a qualified specialist workshop.</p>
The  indicator lamp lights up.	<p>Impermissible operating conditions have been detected in the engine system.</p> <p>One of the following systems is malfunctioning:</p> <ul style="list-style-type: none"> <li>• Engine</li> <li>• Engine cooling</li> <li>• Engine management</li> <li>• Diesel injection system</li> </ul> <p>► If further indicator lamps are displayed, take the combination of lamps (see below) into account when evaluating the cause.</p> <p>► Have the systems checked at a qualified specialist workshop.</p>
The  indicator lamp lights up.	<p>A malfunction has been detected in the electric power supply.</p> <p>► If there are no malfunctions, the indicator lamp goes out after the engine is started.</p> <p>► If the indicator lamp does not go out or if it lights up when the engine is running, have the cause of the malfunction repaired at a qualified specialist workshop.</p>
The  indicator lamp lights up.	<p>A malfunction was detected in the supply of engine lubricating oil.</p> <p>► If there are no malfunctions, the indicator lamp goes out after the engine is started.</p> <p>► If the indicator lamp does not go off or lights up when the engine is running, switch off the engine.</p> <p>► Check the engine oil level (► page 23).</p> <p>► If this does not help, have the malfunction rectified at a qualified specialist workshop.</p>
The  indicator lamp lights up.	<p>A malfunction in the coolant circuit has been detected. The coolant level is too low.</p> <p>► If there are no malfunctions, the indicator lamp goes out after the engine is started.</p> <p>► If the indicator lamp does not go off or lights up when the engine is running, switch off the engine.</p> <p>► Check coolant level (► page 24).</p> <p>► If this does not help, have the malfunction rectified at a qualified specialist workshop.</p>



























Problem	Possible causes/consequences and ► Solutions
The  indicator lamp lights up.	<p>A malfunction in the coolant circuit has been detected. The coolant temperature is too high.</p> <ul style="list-style-type: none"> <li>► If there are no malfunctions, the indicator lamp goes out after the engine is started.</li> <li>► If the indicator lamp does not go off or lights up when the engine is running, switch off the engine.</li> <li>► Check coolant level.</li> <li>► If this does not help, have the malfunction rectified at a qualified specialist workshop.</li> </ul> <p>If you do not observe the instructions, engine performance and torque may be limited.</p>
The  indicator lamp lights up.	<p>The indicator lamp shows the status of the engine oil level. The engine oil level is low.</p> <ul style="list-style-type: none"> <li>► The indicator lamp lights up after the electronic oil level measurement has been completed and a "low oil level" has been determined.</li> <li>► Correct the engine oil level (&gt; page 23).</li> <li>► If this does not help, have the malfunction rectified at a qualified specialist workshop.</li> </ul>
The  indicator lamp flashes.	<p>The indicator lamp shows the status of the engine oil level. The engine oil level is too low.</p> <ul style="list-style-type: none"> <li>► The indicator lamp lights up after the electronic oil level measurement has been completed and "oil level too low" has been determined.</li> <li>► Do not start the engine.</li> <li>► Correct the engine oil level (&gt; page 23).</li> <li>► If this does not help, have the malfunction rectified at a qualified specialist workshop.</li> </ul>
The  indicator lamp lights up.	<p>The indicator lamp shows the status of the continuous brake.</p> <ul style="list-style-type: none"> <li>► The indicator lamp lights up after activation of the continuous brake.</li> <li>► Observe the information contained in the operating instructions of the device/vehicle.</li> <li>► If the indicator lamp does not go out after deactivation or if it lights up permanently, there is a malfunction.</li> <li>► Have the malfunction rectified immediately at a specialist workshop.</li> </ul>
The  indicator lamp lights up.	<p>The indicator lamp shows the status of the cruise control function.</p> <ul style="list-style-type: none"> <li>► The indicator lamp lights up after activation of cruise control.</li> <li>► Observe the information contained in the operating instructions of the device/vehicle.</li> </ul>

Problem	Possible causes/consequences and ► Solutions
The  indicator lamp lights up.	<p>The indicator lamp shows the status of the variable speed limiter.</p> <ul style="list-style-type: none"> <li>► The indicator lamp lights up after a speed limit was activated by the speed limiter.</li> <li>► The active speed limit is shown in the vehicle/device display.</li> <li>► Observe the information contained in the operating instructions of the device/vehicle.</li> </ul>
The  indicator lamp flashes.	<p>The indicator lamp shows that the speed set by the speed limiter has been exceeded.</p> <ul style="list-style-type: none"> <li>► The maximum speed (speed limit) set by the speed limiter is being exceeded by more than 3 km/h. If necessary, reduce speed by adaptive braking.</li> <li>► The speed limit set by the speed limiter was temporarily deactivated by kickdown and may be exceeded. By briefly switching to idling position, the set speed limit is reactivated.</li> <li>► Observe the information contained in the operating instructions of the device/vehicle.</li> </ul>
The  indicator lamp lights up.	<p>The indicator lamp shows the status of the power take-off.</p> <ul style="list-style-type: none"> <li>► The indicator lamp lights up after engaging power take-off.</li> <li>► If there are no malfunctions, the indicator lamp goes out after the power take-off is switched off.</li> <li>► Observe the information contained in the operating instructions of the device/vehicle.</li> </ul>

**Only for vehicles/devices with AdBlue®/DEF reserve level warning lamp (not for EU Stage IIIA)**

If a malfunction is detected and the listed indicator lamps light up, a warning buzzer sounds for approximately 5 seconds. In the event of an emergency, operating restrictions (limitation of the engine torque and engine speed) can be temporarily overridden with the emergency switch (► page 28).

Problem	Possible causes/consequences and ► Solutions
Indicator lamps  and  are lit and  flashes.	<p>The AdBlue<sup>®</sup>/DEF level has dropped to approximately 7.5%. Reduced engine output is active. The engine torque is limited to a maximum of 75% across the whole engine speed range. The limitation takes effect by means of a ramp function.</p> <ul style="list-style-type: none"> <li>► Adapt your driving/operating style.</li> <li>► Top up the AdBlue<sup>®</sup>/DEF tank immediately.</li> </ul> <p>If you do not follow the instructions, an engine speed limitation may be imposed.</p>
The  indicator lamp is lit and  and  are flashing.	<p>The AdBlue<sup>®</sup>/DEF level has dropped to approximately 5%. The reduction in engine output and limitation of the engine torque are activated. The engine torque is limited to a maximum of 50% across the whole engine speed range. The engine speed is limited to a maximum of 60%. The limitation takes effect by means of a ramp function.</p> <ul style="list-style-type: none"> <li>► Adapt your driving/operating style.</li> <li>► Top up the AdBlue<sup>®</sup>/DEF tank immediately.</li> </ul> <p>If you do not observe the instructions, engine torque and engine speed may be further reduced.</p>
The  and  indicator lamps are lit and  and  are flashing.	<p>The AdBlue<sup>®</sup>/DEF level has dropped to approximately 2.5%. The reduction in engine output and limitation of the engine torque are activated. The engine torque is limited to a maximum of 20% across the whole engine speed range. The engine speed is limited to idling speed. The limitation takes effect by means of a ramp function.</p> <ul style="list-style-type: none"> <li>► Adapt your driving/operating style.</li> <li>► Top up the AdBlue<sup>®</sup>/DEF tank immediately.</li> </ul>
The  ,  ,  and  indicator lamps are flashing.	<p>The AdBlue<sup>®</sup>/DEF level has dropped to approximately 0%. The reduction in engine output and limitation of the engine torque are activated. The engine torque is limited to a maximum of 20% across the whole engine speed range. The engine speed is limited to idling speed. The limitation takes effect by means of a ramp function.</p> <ul style="list-style-type: none"> <li>► Stop the vehicle/device, paying attention to road and traffic conditions.</li> <li>► Top up the AdBlue<sup>®</sup>/DEF tank immediately.</li> </ul>
The  indicator lamp lights up.	<p>An emissions-relevant malfunction in the exhaust gas aftertreatment system or in the AdBlue<sup>®</sup>/DEF supply has been detected.</p> <ul style="list-style-type: none"> <li>► Have the exhaust gas aftertreatment system checked at a qualified specialist workshop. Have the malfunction rectified immediately. If you do not, engine output may be reduced and engine speed may be limited.</li> </ul> <p>If there are no malfunctions, the indicator lamp only goes out after further test routines. The system check may involve several engine starts, hours or journeys without a malfunction.</p>





Problem	Possible causes/consequences and ► Solutions
The  indicator lamp lights up and  is flashing.	<p>You have not rectified an emissions-relevant malfunction that has been detected in the exhaust gas aftertreatment system or in the AdBlue®/DEF supply.</p> <p>Reduced engine output is active. The engine torque is limited to a maximum of 75% across the whole engine speed range. The limitation takes effect by means of a ramp function.</p> <ul style="list-style-type: none"> <li>► Adapt your driving/operating style.</li> <li>► Drive carefully to the nearest qualified specialist workshop and have the malfunction rectified immediately.</li> </ul> <p>If you do not follow the instructions, an engine speed limitation may be imposed.</p>
The  and  indicator lamps are flashing.	<p>You have not rectified an emissions-relevant malfunction that has been detected in the exhaust gas aftertreatment system or in the AdBlue®/DEF supply.</p> <p>The reduction in engine output and limitation of the engine torque are activated. The engine torque is limited to a maximum of 50% across the whole engine speed range. The engine speed is limited to a maximum of 60%. The limitation takes effect by means of a ramp function.</p> <ul style="list-style-type: none"> <li>► Adapt your driving/operating style.</li> <li>► Drive carefully to the nearest qualified specialist workshop and have the malfunction rectified immediately.</li> </ul> <p>If you do not follow the instructions, an engine speed limitation may be imposed.</p>
The  and  indicator lamps are flashing and  lights up.	<p>You have not rectified an emissions-relevant malfunction that has been detected in the exhaust gas aftertreatment system or in the AdBlue®/DEF supply.</p> <p>The reduction in engine output and limitation of the engine torque are activated. The engine torque is limited to a maximum of 20% across the whole engine speed range. The engine speed is limited to idling speed.</p> <ul style="list-style-type: none"> <li>► Adapt your driving/operating style.</li> <li>► Have the malfunction rectified immediately at a specialist workshop.</li> </ul>
The  ,  and  indicator lamps are flashing.	<p>You have not rectified an emissions-relevant malfunction that has been detected in the exhaust gas aftertreatment system or in the AdBlue®/DEF supply.</p> <p>Reduced engine output is active. The engine torque is limited to a maximum of 20% across the whole engine speed range. The engine speed is limited to idling speed.</p> <ul style="list-style-type: none"> <li>► Stop the vehicle/device, paying attention to road and traffic conditions.</li> <li>► Have the malfunction rectified immediately at a specialist workshop.</li> </ul>





When the AdBlue®/DEF tank is filled or the fault is rectified, full engine power will be available again. If the system check does not detect any other faults, the indicator lamps go out after the system's

status indicator. The system check may involve several engine starts, several hours or several journeys without a malfunction.

### Only for vehicles/devices without AdBlue<sup>®</sup>/DEF reserve level warning lamp (not for EU Stage IIIA)

If a malfunction is detected and the listed indicator lamps light up, a warning buzzer sounds for approximately 5 seconds. In the event of an emergency, operating restrictions (limitation of the engine torque and engine speed) can be temporarily overridden with the emergency switch (▷ page 28).

Problem	Possible causes/consequences and ► Solutions
The  indicator lamp lights up.	<p>An emissions-relevant malfunction in the exhaust gas aftertreatment system or in the AdBlue<sup>®</sup>/DEF supply has been detected.</p> <ul style="list-style-type: none"> <li>► Top up the AdBlue<sup>®</sup>/DEF tank immediately.</li> <li>► If this does not help: have the exhaust gas aftertreatment system checked at a qualified specialist workshop. Have the malfunction rectified immediately. If you do not, engine output may be reduced and engine speed may be limited.</li> </ul> <p>If there are no malfunctions, the indicator lamp only goes out after further test routines. The system check may involve several engine starts, hours or journeys without a malfunction.</p>
The  indicator lamp is flashing and  lights up.	<p>You have not rectified an emissions-relevant malfunction that has been detected in the exhaust gas aftertreatment system or in the AdBlue<sup>®</sup>/DEF supply.</p> <p>Reduced engine output is active. The engine torque is limited to a maximum of 75% across the whole engine speed range. The limitation will take effect the next time the engine is started.</p> <ul style="list-style-type: none"> <li>► Adapt your driving/operating style.</li> <li>► Top up the AdBlue<sup>®</sup>/DEF tank immediately.</li> <li>► If this does not help, have the malfunction rectified at a qualified specialist workshop.</li> </ul> <p>If you do not follow the instructions, an engine speed limitation may be imposed.</p>
The  and  indicator lamps are flashing.	<p>You have not rectified an emissions-relevant malfunction that has been detected in the exhaust gas aftertreatment system or in the AdBlue<sup>®</sup>/DEF supply.</p> <p>The reduction in engine output and limitation of the engine torque are activated. The engine torque is limited to a maximum of 50% across the whole engine speed range. The engine speed is limited to a maximum of 60%. The limitation takes effect by means of a ramp function.</p> <ul style="list-style-type: none"> <li>► Adapt your driving/operating style.</li> <li>► Top up the AdBlue<sup>®</sup>/DEF tank immediately.</li> <li>► If this does not help, have the malfunction rectified at a qualified specialist workshop.</li> </ul> <p>If you do not follow the instructions, an engine speed limitation may be imposed.</p>

Problem	Possible causes/consequences and ► Solutions
The  and <b>LIMIT</b> indicator lamps are flashing and  lights up.	<p>You have not rectified an emissions-relevant malfunction that has been detected in the exhaust gas aftertreatment system or in the AdBlue<sup>®</sup>/DEF supply.</p> <p>The reduction in engine output and limitation of the engine torque are activated. The engine torque is limited to a maximum of 20% across the whole engine speed range. The engine speed is limited to idling speed.</p> <ul style="list-style-type: none"> <li>► Adapt your driving/operating style.</li> <li>► Top up the AdBlue<sup>®</sup>/DEF tank immediately.</li> <li>► If this does not help, have the malfunction rectified at a qualified specialist workshop.</li> </ul>
The  , <b>LIMIT</b> and  indicator lamps are flashing.	<p>You have not rectified an emissions-relevant malfunction that has been detected in the exhaust gas aftertreatment system or in the AdBlue<sup>®</sup>/DEF supply.</p> <p>The reduction in engine output and limitation of the engine torque are activated. The engine torque is limited to a maximum of 20% across the whole engine speed range. The engine speed is limited to idling speed.</p> <ul style="list-style-type: none"> <li>► Stop the vehicle/device, paying attention to road and traffic conditions.</li> <li>► Have the malfunction rectified immediately at a specialist workshop.</li> </ul>

When the AdBlue<sup>®</sup>/DEF tank is filled or the fault is rectified, full engine power will be available again. If the system check does not detect any other faults, the indicator lamps go out after the system's status indicator. The system check may involve several engine starts, several hours or several journeys without a malfunction.

If the system check does not detect any other faults, the indicator lamps go out after the system's status indicator.

## Operating instructions

### Running-in

Observe the vehicle/device manufacturer's running-in notes. The running-in period of the engine has a significant effect on the vehicle/device, especially with regard to:

- service life
- operating safety
- economy

Observe the following notes during the running-in period up to 2,000 km (30 operating hours):

- avoid subjecting the engine to full load.
- run in the engine with care, using differing speeds and engine revs.

- avoid high engine speeds.
- do not drive at more than  $\frac{3}{4}$  of the maximum road speed for each gear.
- change gear in good time.
- do not shift down to brake the vehicle.
- for vehicles with automatic transmission, do not depress the accelerator pedal beyond the point of resistance (kickdown).

After 2,000 km (30 operating hours), you can gradually bring the vehicle/device up to full output and increased engine speeds.

## Fuel consumption

### General notes

Fuel consumption depends on:

- the machine version/vehicle version
- the operating conditions
- the attached equipment (e.g. hydraulic pumps, mowers, etc.)
- maintenance
- driving resistance
- your driving style

For these reasons, exact details about any single engine's fuel consumption cannot be provided.

### Machine version/vehicle version

The following components affect fuel consumption:

- tyres (e.g. tyre pressure, tyre condition)
- body type
- drive train (e.g. transmission ratio)
- additional equipment (e.g. automatic climate control, auxiliary heating)

### Maintenance

Fuel consumption and assembly wear depend on how often maintenance is carried out. Regular maintenance increases safety and lowers fuel consumption. Keep to the maintenance intervals. Always have maintenance work carried out at a qualified specialist workshop.

### Fuel type

The fuel grade also affects fuel consumption. Use of lower fuel grades and/or non-approved fuel additives will increase fuel consumption. When refuelling, ensure that you are filling the appropriate fuel grade (▷ page 44).

### AdBlue®/DEF consumption (not for EU Stage IIIA)

AdBlue® consumption is between 2 and 4% of the fuel consumption, depending on engine use.

## Engine oil consumption

After running-in the engine, oil consumption may reach 0.2% of the vehicle's actual fuel consumption.

More arduous operating conditions and increased distance covered could result in engines exceeding this oil consumption value.

### Warning buzzer

If the warning buzzer sounds and the  symbol on the instrument panel is displayed, the engine's operating safety is jeopardised.

Do not pull away, or stop the vehicle as soon as possible, paying attention to road and traffic conditions. You could otherwise damage the engine.

The warning buzzer sounds depending on the vehicle if:

- you exceed the maximum permissible engine speed.
- the engine speed or vehicle speed is too high when changing gears.
- the coolant level is too low or the maximum permissible coolant temperature (▷ page 62) is exceeded. The operating safety of the engine is jeopardised.
- an emissions-relevant malfunction is detected (not for engines with emissions certification according to EU Stage IIIA) or there is an operating restriction due to an emissions-relevant malfunction.
- the oil level is too low.

## Refuelling

### Fuels

### Important safety notes

#### WARNING

Fuels are poisonous and hazardous to health. There is a danger of injury.

Do not swallow fuel or let it come into contact with skin, eyes or clothing. Do not inhale fuel vapours. Keep fuels out of the reach of children.

If you or others come into contact with fuel, observe the following:

- Wash the fuel off any affected areas of skin with water and soap immediately.
- If you get fuel in your eyes, rinse them thoroughly with clean water immediately. Seek immediate medical attention.
- If fuel is swallowed, seek immediate medical attention. Do not induce vomiting.
- Change any clothing that has come into contact with fuel immediately.

#### **WARNING**

Fuel is highly flammable. Improper handling of fuel creates a risk of fire and explosion.

Avoid fire, naked flames, smoking and creating sparks under all circumstances. Switch off the ignition and auxiliary heating before carrying out work to the fuel system. Always wear protective gloves.

#### **WARNING**

If you mix diesel fuel with petrol, the flash point of this fuel mixture is lower than that of pure diesel fuel. When the engine is running, components in the exhaust system may overheat unnoticed. There is a risk of fire.

Never refuel with petrol. Never add petrol to diesel fuel.

- ❗ Only refuel using commercially available, sulphur-free diesel fuel that complies with the following standards:

- EN 590 as of 2010, et seq. (max. 0.001% sulphur by weight) (10 ppm) or
- ASTM D975 (max. 0.0015% sulphur by weight) (15 ppm)

The following fuel types are not permitted:

- sulphurous fuel with a sulphur content greater than 0.005% by weight (50 ppm)
- marine diesel fuel
- aviation turbine fuel
- heating oils
- fatty acid methyl ester FAME (bio-diesel fuel)

These fuel types cause irreversible damage to the engine and the exhaust gas aftertreatment system (not for EU Stage IIIA) and significantly reduce the expected service life.

- ❗ Do not use petrol to refuel vehicles with a diesel engine. Even small amounts of petrol result in damage to the fuel system and engine.
- ❗ Do not switch on the ignition if you accidentally refuel with the wrong fuel. Otherwise, the fuel will enter the fuel lines. Notify a qualified specialist workshop and have the fuel tank and fuel lines drained completely.
- ❗ Do not add any special fuel additives to the diesel fuel.  
Special fuel additives can lead to:
  - malfunctions
  - damage to the catalytic converter
  - engine damage
- ❗ AdBlue®/DEF is not a fuel additive and must not be added to the diesel tank. If AdBlue®/DEF gets into the diesel tank, this could lead to engine damage.
- ❗ A higher fuel sulphur content accelerates the ageing process of the engine oil and can damage the engine and exhaust system.

#### **Environmental note**

If fuels are handled improperly, they pose a danger to persons and the environment. Do not allow fuels to run into the sewage system, the surface waters, the ground water or into the ground.

Please observe further information on diesel fuel in the "Service products" section (> page 44). Using fuels which have not been approved causes irreversible damage to the engine and the exhaust gas aftertreatment system, as well as also significantly reducing the expected service life.

#### **Before filling the tank**

- ❗ If you are using drums or canisters to refuel the vehicle, you should filter the fuel before adding it.  
This will prevent malfunctions in the fuel system due to contaminated fuel.



- ▶ Switch off the engine.
- ▶ Secure the vehicle/device against rolling away.
- ▶ Observe the fuel grade (> page 44).

Regularly check the fuel prefilter with heated water separator for condensation.

### AdBlue<sup>®</sup>/DEF (not for EU Stage IIIA)

#### Important safety notes

- !** Do not allow diesel fuel to run into the AdBlue<sup>®</sup>/DEF tank. You could otherwise damage the exhaust gas aftertreatment system.
- !** Only use AdBlue<sup>®</sup>/DEF in accordance with DIN 70070/ISO 2224 1. Do not use any additives.  
If AdBlue<sup>®</sup>/DEF comes into contact with painted or aluminium surfaces when filling the tank, rinse the affected area immediately with plenty of water.
- !** Do not mix additives to AdBlue<sup>®</sup>/DEF. Do not dilute AdBlue<sup>®</sup>/DEF with tap water. This could destroy the exhaust gas aftertreatment system.
- !** Always close the AdBlue<sup>®</sup>/DEF tank properly. Otherwise impurities may get into the exhaust gas aftertreatment system and damage it.
- !** Make sure that you do not overfill the AdBlue<sup>®</sup>/DEF tank. Otherwise, the AdBlue<sup>®</sup>/DEF tank could be damaged at very low temperatures.

#### Environmental note

Dispose of AdBlue<sup>®</sup>/DEF in an environmentally responsible manner.

When opening the AdBlue<sup>®</sup>/DEF tank, small amounts of ammonia vapours could escape. Ammonia vapours have a pungent smell and are particularly irritating to:

- skin
- mucous membranes
- eyes

The vapours may cause a burning sensation in the eyes, nose and throat as well as irritation of the throat and watering eyes.

Avoid inhaling ammonia vapours. Only fill the AdBlue<sup>®</sup>/DEF tank in well-ventilated areas.

AdBlue<sup>®</sup>/DEF should not come into contact with skin, eyes or clothing, and should not be swallowed. Keep AdBlue<sup>®</sup>/DEF out of the reach of children.

If you come into contact with AdBlue<sup>®</sup>/DEF, observe the following:

- immediately wash AdBlue<sup>®</sup>/DEF from your skin with water and soap.
- if AdBlue<sup>®</sup>/DEF comes into contact with your eyes, rinse your eyes with clean water immediately. Seek medical attention immediately.
- if you have swallowed AdBlue<sup>®</sup>/DEF, immediately rinse your mouth with water and drink plenty of water. Seek medical attention immediately.
- change clothing that has come into contact with AdBlue<sup>®</sup>/DEF immediately.

AdBlue<sup>®</sup>/DEF is not refilled as part of the maintenance work. Top up the tank regularly during vehicle operation or at the latest when the first event message is displayed on the electronic engine management system.

You will find further information on AdBlue<sup>®</sup>/DEF in the "Service products" section (> page 45).

#### Before filling the tank

- ▶ Switch off the engine.
- ▶ Secure the vehicle/device against rolling away.

Always fill the tank with at least 5 litres, as smaller amounts could cause malfunctions.

### Winter operation

#### Notes for winter operation

- !** At very low outside temperatures, make sure that the engine oil added is of an appropriate SAE classification. Using engine oils that are not suitable for very low outside temperatures may result in engine damage.

Before the start of the cold season, make sure that:

- the coolant contains sufficient antifreeze (> page 43)
- the fuel used is suitable for winter use (> page 44)
- the SAE class of the engine oil used is in accordance with outside temperatures (> page 42).

### Jump-starting

#### WARNING

The use of liquid or gaseous starting aids can cause explosions. This may result in severe injuries.

Do not use liquid or gaseous starting aids such as ether or Startpilot to start the engine.

### Coolant preheating

#### DANGER

There is high voltage in the 230 V power socket if:

- the 230 V power supply is being established
- the residual current circuit breaker is switched on

If you or another person, particularly a child, reach into the power socket, you could receive an electric shock. There is a risk of fatal injuries.

Do not reach into the power socket and keep children away from it. After connecting to the 230 V power supply, make sure that the residual current circuit breaker is functioning correctly.

There is an electrical heating element fitted to the engine for coolant preheating. Coolant preheating serves to help the engine reach operating temperature sooner.

Thanks to a shorter cold-start phase, the engine is operational sooner and engine wear and tear is reduced.

The electrical heating element has power consumption of up to 1.5kW at 230V power supply.

The supply of electrical power is provided by an external (230V) power socket.

Please also observe the information in the Operating Instructions provided by the vehicle/device manufacturer.

### Batteries

Always aim to achieve the full charge status. You can do this by means of careful maintenance and low electrical consumption. The cold start capacity is reduced when it is very cold. For example, at -10 °C it is only around 60% of the normal capacity.

### Diesel fuels

Notes on diesel fuel at low temperatures (> page 45).

## General notes

### WARNING

Before carrying out maintenance or repair work, you must read the relevant sections of the technical documentation relating to maintenance and repair measures, e.g. the Operating Instructions and workshop information. In particular, first familiarise yourself with the legal regulations, e.g. work safety and accident prevention regulations. You could otherwise fail to recognise dangers and injure yourself or others. Always have maintenance work carried out at a qualified specialist workshop.

### WARNING

If you do not have the prescribed service/maintenance work or necessary repairs carried out, this could result in malfunctions or system failures. There is a risk of an accident. Always have the prescribed service/maintenance work as well as necessary repairs carried out at a qualified specialist workshop.

### WARNING

Limbs could be crushed or trapped if the engine is started unintentionally during service or maintenance work. There is a risk of injury. Always secure the engine against unintentional starting before carrying out maintenance or repair work.

### WARNING

Cloths or other flammable materials left in the engine compartment can ignite if they come into contact with the exhaust system or parts of the engine that heat up. There is a risk of fire. After carrying out maintenance work, make sure that no extraneous flammable material is left in the engine compartment or on the exhaust system.

### Environmental note

If circumstances require you to do some maintenance work yourself, you must observe the environmental protection requirements. When disposing of service products, e.g. engine oil, you must comply with the legal requirements. This also concerns all parts, e.g. filters, that have been in contact with service products.

Dispose of empty containers, cleaning cloths and care products in an environmentally responsible manner.

Observe the instructions for care products.

Do not let the engine run longer than necessary when stationary.

Like all technical equipment, the engine system requires care and maintenance.

The scope and frequency of maintenance work depends mainly on:

- the widely varying operating conditions.
- the service products used.

 All maintenance intervals and work refer to genuine Mercedes-Benz parts. They also refer to accessory parts and service products that have been expressly approved by Mercedes-Benz for the engine.

Inspection and maintenance work requires special skills that cannot be acquired by reading these Operating Instructions. Always have this work and maintenance work carried out by a qualified specialist workshop.

Have any work that is carried out confirmed with an entry in the Maintenance Booklet. This proof of regular maintenance is always required for any warranty claims.

Instructions and important information on carrying out maintenance work can be found in the Workshop Information System (WIS) on the Internet. Make sure that you have access to this information when carrying out maintenance work. Information on WIS (▷ page 8).

Please also observe the maintenance instructions for special accessories.

When working on the vehicle, comply with all safety regulations, such as operating instructions, regulations concerning hazardous materials, environmental protection measures, work safety and accident prevention regulations.

## Service products

### Important safety notes

#### WARNING

Service product can be poisonous and hazardous to health. There is a risk of injury.

Observe the instructions on the respective original container when using, storing and disposing off service products. Always store service products in the sealed original container. Always keep service products out of the reach of children.

- !** Special additives (except approved fuel additives) are neither required nor approved for use with approved service products. Additives may cause damage to major assemblies. Therefore, do not mix any additives with service products. You are responsible for the results of using fuel additives.

#### Environmental note

Dispose of service products in an environmentally-responsible manner.

Service products are:

- fuels (e.g. diesel)
- lubricants (e.g. engine oil, transmission oil, grease)
- coolant, antifreeze
- AdBlue<sup>®</sup>/DEF, reducing agent in the exhaust gas aftertreatment system (not for EU Stage IIIA)

Approved operating fluids fulfil the highest quality standards and are documented in the Mercedes-Benz Specifications for Service Products. Therefore, only use service products approved for the vehicle. Information about approved service products is available from any MTU or MTU-authorized Mercedes-Benz Service Centre (▷ page 8).

You can recognise operating fluids approved by Mercedes-Benz by the following inscription on the container:

- MB-Freigabe (e.g. MB-Freigabe 229.51)
- or
- MB-Approval (z. B. MB-Approval 229.51)

Other labels and recommendations relating to the quality or indicating that the product meets a certain specification are not necessarily

approved by Mercedes-Benz. Further information is available at any MTU or MTU-authorized Mercedes-Benz Service Centre (▷ page 8).

- i** Information about service products which have been tested by Mercedes-Benz and approved for your engine system can be found in the Mercedes-Benz Specifications for Service products on the Internet at: <http://bevo.mercedes-benz.com/>.
- i** The specification and availability of lubricants may vary. Individual lubricants may no longer be available, especially for older engines. Information is available from any MTU or MTU-authorized Service Centre (▷ page 8).

## Engine oils

### Notes on engine oils

- !** Engine oils other than those of the quality specified in this Operator's Manual are not permitted.

The oil quality is crucial for the function and service life of an engine. Based on highly exacting tests, Mercedes-Benz regularly approves engine oils which fulfil the current technical standards. Only use engine oils in accordance with Sheet No. 228.51, 228.31, 228.5 or 228.3 of the Mercedes-Benz Specifications for Service Products.

Engine oils according to Sheet No. 228.51 and 228.5 have a higher quality standard and have a favourable effect on:

- length of oil change intervals
- engine wear
- fuel consumption
- exhaust emissions

Before delivery, the engine is filled with oil in SAE class 5W-30 (▷ page 23).

Check the vehicle assemblies for leaks regularly. If fluid loss is identified, e.g. by oil drops on the parking area, have the cause of the fluid loss rectified at a qualified specialist workshop.

### Scope of application

Multi-grade engine oils compliant with Sheet No. 228.51, 228.31, 228.5 or 228.3 can be used all year round.

## Oil change

**!** If you mix engine oils with differing oil grades, the change interval for the engine oil is reduced in comparison to mixtures of engine oil of identical grade.

Therefore, only mix engine oils of differing grade in exceptional circumstances. To prevent damage to the engine, the maintenance intervals must be adjusted accordingly.

**!** If the SAE class (viscosity) of the engine oil used is not suitable for continually low outside temperatures below  $-20\text{ }^{\circ}\text{C}$ , this could cause engine damage.

The specified temperatures of the SAE class always refer to freshly added oil. Engine oil ages during driving due to soot and fuel residue. This impairs the characteristics of the engine oil, particularly at low outside temperatures.

If the outside temperature is under  $-20\text{ }^{\circ}\text{C}$ , Mercedes-Benz strongly recommends using engine oils of SAE class 5W-30 or 0W-30.

Use only all-season oils.

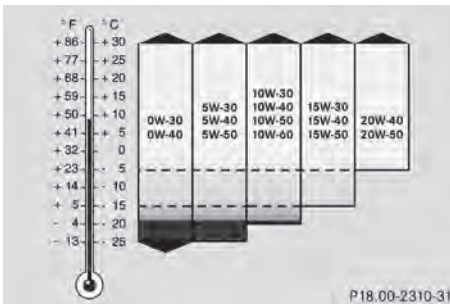

Engine oil SAE classes (viscosity)

► Select the SAE class (viscosity) of the engine oil to suit the average outside temperatures for the time of year.

Oil change intervals are dependent on the following:

- the operating conditions of the vehicle
- the grade of the engine oil used

The maximum oil change interval can only be achieved by using engine oils of particularly high quality in accordance with Sheet No. 228.5 1 and 228.5 of the Mercedes-Benz Specifications for Service Products. The classification of oil change intervals is specified in the Maintenance Booklet.

## Adding/topping up the engine oil

**!** There is a risk of damage to the catalytic converter or to the engine if too much oil is added. Have excess oil drained off.

When topping up, Mercedes-Benz recommends that you only use engine oil of the same grade and SAE class as the oil filled at the last oil change.

Check the oil level before topping up the engine oil (► page 23).

## Miscibility of engine oils

The benefits of high-quality engine oils are diminished if you mix them.

Engine oils are differentiated according to:

- engine oil brand
- quality grade (Sheet No.)
- SAE viscosity class

If, in exceptional circumstances, the type of engine oil currently used in the engine is not available, another mineral or synthetic engine oil may be used. Make sure it is approved for Mercedes-Benz.

Please observe the following: if you top up with an engine oil of a lower quality, the maintenance interval corresponding to the lower quality (Sheet No.) must be used. The maintenance interval is reduced. If you top up with an engine oil of a higher quality, the maintenance interval is not altered.

Observe the notes in the Maintenance Booklet.

## Coolant

### **!** WARNING

The cooling system is pressurised, particularly when the engine is warm. If you open the cap, you could be scalded if hot coolant sprays out. There is a risk of injury.

Let the engine cool down before you open the cap. Wear gloves and eye protection. Open the cap slowly to release the pressure.

### **!** WARNING

If antifreeze comes into contact with hot components in the engine compartment, it may ignite. There is a risk of fire and injury.

Let the engine cool down before you top up the antifreeze. Make sure that antifreeze is not spilled next to the filler neck. Thoroughly clean the antifreeze from components before starting the engine.

A coolant that ensures anti-corrosion/antifreeze protection and other important protective effects is filled at the factory.

The coolant is a mixture of water and corrosion inhibitor/antifreeze.

The corrosion inhibitor/antifreeze in the coolant has the following properties:

- heat transfer
- anti-corrosion protection
- cavitation protection (protection against pitting)
- antifreeze protection
- raising the boiling point

Leave the coolant in the engine cooling system all year round – even in countries with high outside temperatures.

Check the corrosion inhibitor/antifreeze concentration in the coolant every six months.

Renew the coolant at the interval specified in the Maintenance Booklet.

Only use approved corrosion inhibitor/antifreeze agents (> page 63). Please note the Mercedes-Benz Specifications for Service Products (> page 42). This prevents damage to the engine cooling system and engine.

When renewing the coolant, ensure that it contains 50% corrosion inhibitor/antifreeze by volume. This corresponds to antifreeze protection down to -37 °C.

Do not exceed 55% by volume (antifreeze down to approximately -45 °C). The heat dissipation and antifreeze may otherwise be negatively affected.

If there is a loss of coolant, do not top it up by using only water, but also add an approved corrosion inhibitor/antifreeze agent.

The water in the coolant must meet certain requirements, which are often fulfilled by the use of drinking water. The water must be treated if its quality does not meet the required standards.

Please note the Mercedes-Benz Specifications for Service Products, Sheet No. 310.1.

Mixtures with other corrosion inhibitors/antifreeze agents are not permitted.

## Diesel fuels

### Important safety notes

#### WARNING

Fuel is highly flammable. Improper handling of fuel creates a risk of fire and explosion.

Avoid fire, naked flames, smoking and creating sparks under all circumstances. Switch off the engine and, if applicable, the auxiliary heating before refuelling.

#### WARNING

Fuels are poisonous and hazardous to health. There is a danger of injury.

Do not swallow fuel or let it come into contact with skin, eyes or clothing. Do not inhale fuel vapours. Keep fuels out of the reach of children.

If you or others come into contact with fuel, observe the following:

- Wash the fuel off any affected areas of skin with water and soap immediately.
- If you get fuel in your eyes, rinse them thoroughly with clean water immediately. Seek immediate medical attention.
- If fuel is swallowed, seek immediate medical attention. Do not induce vomiting.
- Change any clothing that has come into contact with fuel immediately.

 If you are using drums or canisters to refuel the vehicle, you should filter the fuel before filling.

This prevents malfunctions in the fuel system caused by contaminated fuel.

 Only refuel using commercially available, sulphur-free diesel fuel that complies with the following standards:

- EN 590 as of 2010, et seq. (max. 0.001% sulphur by weight) (10 ppm) or
- ASTM D975 (max. 0.0015% sulphur by weight) (15 ppm)

The following fuel types are not permitted:

- sulphurous fuel with a sulphur content greater than 0.005% by weight (50 ppm)
- marine diesel fuel

- aviation turbine fuel
- heating oils
- fatty acid methyl ester FAME (bio-diesel fuel)

These fuel types cause irreversible damage to the engine and the exhaust gas aftertreatment system (not for EU Stage IIIA) and significantly reduce the expected service life.

**!** A higher fuel sulphur content accelerates the ageing process of the engine oil and can damage the engine and exhaust system.

### Fuel grade

**i** Certain countries have diesel fuel with varying sulphur contents. Diesel fuel with low fuel-sulphur content is sold in certain countries under the name "Euro diesel".

Information about current country-specific sulphur contents can be obtained from any MTU or MTU-authorized Mercedes-Benz Service Centre (▷ page 8).

### Water content

The maximum permissible water content at the point of transfer between vehicle and engine must not be greater than 200 mg/kg. If the water content is higher, an additional water separator must be fitted on the chassis.

If the engine is operated with increased amounts of dirt and water, an additional fuel prefilter with a water separator must be fitted on the chassis.

### Diesel fuels at low temperatures

#### **!** WARNING

If you heat fuel system components, e.g. with a hot-air gun or naked flame, these components could be damaged. This can cause fuel to escape and ignite. Depending on the type of damage, fuel may also not escape until the engine is running. There is a risk of fire and explosion.

Never heat fuel system components. Contact a qualified specialist workshop to rectify the malfunction.

At low outside temperatures, paraffin separation may cause the flow properties of the diesel fuel to be insufficient.

To prevent operating problems, diesel fuel with improved flow properties is available in the winter months.

Winter diesel fuels are reliable down to outside temperatures of  $-22\text{ °C}$  in Germany and other Central European countries. You can normally use winter diesel fuel without problems at the outside temperatures expected in the country where it is on sale.

### Fuel additives

**!** When necessary, use only approved fuel additives.

There is otherwise a risk of impaired engine performance or engine and catalytic converter damage. The use of appropriate fuel additives is your responsibility.

**!** Do not add any petrol or kerosene to diesel fuel to improve its flow characteristics. Petrol or kerosene impairs the lubricity of the diesel fuel. This can cause damage to the injection system, for example.

For lower temperatures, the engine can be equipped with a fuel preheating system. This improves the flow characteristics of the diesel fuel according to the output of the installed heater.

Fuel additives used to improve flow characteristics are flow improvers.

Do not add flow improvers to winter diesel fuel guaranteed to operate down to  $-22\text{ °C}$ . The cold flow properties of the fuel may deteriorate as a consequence of the flow improver.

### AdBlue®/DEF (not for EU Stage IIIA)

#### Important safety notes

#### **!** WARNING

AdBlue®/DEF must not come into contact with skin, eyes or clothing.

- If AdBlue®/DEF comes into contact with your eyes or skin, rinse affected areas with clean water immediately.
- If AdBlue®/DEF is swallowed, immediately rinse your mouth out with a lot of clean water and drink plenty of water.

- Change clothing that is soiled with AdBlue®/DEF immediately.
- If allergic reactions occur, consult a doctor immediately.

Keep AdBlue®/DEF out of the reach of children.

**!** Only use AdBlue®/DEF in accordance with DIN 70070/ISO 2224 1. Do not use any additives.

If AdBlue®/DEF comes into contact with painted or aluminium surfaces when filling the tank, rinse the affected area immediately with plenty of water.

The terms "Urea" and "DEF" (Diesel Exhaust Fluid) are also used for "AdBlue®".

If the AdBlue®/DEF tank is full of AdBlue®/DEF, pressure compensation may occur when the tank lid is unscrewed. AdBlue®/DEF may spill out. Therefore, open the AdBlue®/DEF tank lid carefully. If AdBlue®/DEF spills out, immediately wash the affected area with plenty of water.

When opening the AdBlue®/DEF tank, small amounts of ammonia vapours could escape.

Ammonia vapours have a pungent smell and are particularly irritating to:

- skin
- mucous membranes
- eyes

The vapours may cause a burning sensation in the eyes, nose and throat as well as irritation of the throat and watering eyes.

Avoid inhaling ammonia vapours. Only fill the AdBlue®/DEF tank in well-ventilated areas.

AdBlue®/DEF should not come into contact with skin, eyes or clothing, and should not be swallowed. Keep AdBlue® out of the reach of children.

If you come into contact with AdBlue®/DEF, observe the following:

- immediately wash AdBlue®/DEF from your skin with water and soap.
- if AdBlue®/DEF comes into contact with your eyes, rinse your eyes with clean water immediately. Seek medical attention immediately.
- if you have swallowed AdBlue®/DEF, immediately rinse your mouth with water and drink

plenty of water. Seek medical attention immediately.

- change clothing that has come into contact with AdBlue®/DEF immediately.

## High outside temperatures

### WARNING

If the AdBlue®/DEF tank cap is opened at high temperatures, ammonia vapours may escape.

Ammonia vapours have a pungent odour and particularly irritate:

- skin
- mucous membranes
- eyes

The vapours may cause a burning sensation in the eyes, nose and throat as well as irritation of the throat and watering eyes.

Avoid inhaling ammonia vapours.

The chemical composition of AdBlue®/DEF can break down if it heats up to 50 °C over a long period (e.g. as a result of direct sunlight on the tank). This creates ammonia vapour.

## Low outside temperatures

AdBlue®/DEF freezes at a temperature of approximately -11 °C .

Depending on equipment and country, the AdBlue®/DEF supply system of the vehicle may be heated; see the vehicle Owner's Manual.

Winter operation is thus guaranteed at temperatures below -11 °C .

## Additives, tap water

**!** Do not mix additives to AdBlue®/DEF. Do not dilute AdBlue®/DEF with tap water. This could destroy the exhaust gas aftertreatment system.

## Storage

**!** Containers made of the following materials are not suited to storing AdBlue®:

- aluminium
- copper
- copper alloys



- unalloyed steel
- galvanised steel

If stored in these types of containers, constituents of these metals may dissolve and cause irreparable damage to the exhaust gas after-treatment.

Only use containers made of the following materials to store AdBlue®:

- Cr-Ni steel in accordance with DIN EN 10 088-1/2/3
- Mo-Cr-Ni steel in accordance with DIN EN 10 088-1/2/3
- Polypropylene
- Polyethylene

### Disposal



#### Environmental note

Dispose of AdBlue®/DEF in an environmentally responsible manner.

Observe laws and regulations on the disposal of AdBlue®/DEF in the country concerned.

### Purity

**!** Impurities in AdBlue®/DEF, e.g. due to other service products, cleaning products or dust, may lead to:

- increased emission values
- damage to the catalytic converter
- engine damage
- malfunctions in the exhaust gas after-treatment system.

Ensure that AdBlue®/DEF is always pure to avoid malfunctions in the exhaust gas after-treatment system.

If AdBlue®/DEF is pumped from the tank, e.g. during repairs, do not use this fluid to refill the tank. Otherwise the purity of the fluid would no longer be guaranteed.

## Cleaning and care

### Notes on care

Regular care helps to maintain the value of the engine.

Mercedes-Benz recommends that you only use care products that have been tested and approved for Mercedes-Benz. You can obtain these care products from any MTU or MTU-authorized Mercedes-Benz Service Centre (▷ page 8).

### High-pressure cleaning



#### Environmental note

Only wash your vehicle at a wash bay designed for this purpose. Dispose of empty containers and used cleaning products in an environmentally responsible manner.

**!** When cleaning, never point the water jet at the exhaust pipe. The system may otherwise be damaged.

**!** When using a high-pressure cleaner, keep a minimum distance between the high-pressure nozzle and the engine parts. Otherwise, parts of the engine may be damaged.

Observe the following minimum distances:

- about 70 cm with round-spray jets
- about 30 cm with 25° flat-spray jets
- about 30 cm with concentrated-power jets

**!** Keep the water jet moving constantly while cleaning. In this way, you will avoid causing damage.

Do not point the water jet at:

- electrical components
- plug connectors
- seals
- hoses

### Cleaning the engine

**!** Observe the following notes when cleaning the engine. This avoids malfunctions and damage to the engine.

- When using high-pressure or steam cleaners, do not point the spray directly at electrical components and electric cables.
- Make sure that no water enters the air intake and ventilation openings.
- Treat the engine with preservative agents after it has been cleaned. When doing so,

protect the belt drive system from the preservative agent.

- Only use wax-based protective agents for engines that comply with Sheet No. 385.4 of the Mercedes-Benz Specifications for Service Products.

In addition, observe the notes in the "High-pressure cleaning" section (▷ page 47).

### General notes

Special measures are required to decommission the engine/vehicle.

**Information about batteries:** if the engine/vehicle is to be out of use for longer than three weeks, disconnect the negative terminal on the battery. This prevents the batteries from being discharged by no-load current consumers.

If the engine/vehicle is to be out of use for a longer period, remove the batteries and store them in a dry and well-ventilated area.

Recharge batteries every 3 months at the latest. Ensure that there is adequate ventilation when recharging. Check the battery fluid levels before and after charging and if necessary correct them. For further information (▷ page 39).

### Decommissioning for up to 6 months

When decommissioning an engine/vehicle, keep it in a covered, dry and well-ventilated area. The room temperature should not fall below -10 °C.

#### Measures prior to decommissioning:

- Clean the engine/vehicle thoroughly.
- Remove any patches of corrosion from the engine.
- Change the engine oil and oil filter if the last oil change was carried out more than 20,000 km (or around 300 operating hours) ago.

Also change the engine oil and oil filter if the oil is more than 12 months old.

- Check and adjust the level of coolant or renew coolant.
- Check and correct the corrosion inhibitor/antifreeze agent content in the coolant.
- Add AdBlue<sup>®</sup>/DEF until the tank is full, to prevent AdBlue<sup>®</sup>/DEF from crystallising (not for EU Stage IIIA).
- Drain the water separator for the fuel system.

#### Measures during decommissioning:

Start the engine at least once a month and leave it running for 15 - 30 minutes at around 900 rpm.

Depending on the vehicle's equipment:

- with the air-conditioning system switched on
- with the heating activated
- with the auxiliary heating switched on

The monthly engine start can be omitted if the engine was operated with FAME-free fuel (B0 diesel fuel/with no biodiesel content <sup>2</sup>) and subsequently decommissioned.

The engine oil level and the coolant level must be checked before every engine start. On vehicles/devices with a water separator on the fuel filter or fuel prefilter, additionally drain the water separator, if necessary. Upon starting and while the engine is running, observe the oil pressure as well as the coolant temperature.

#### Measures prior to recommissioning:

- Fit and connect the battery.
- Check that the electrical system is functioning correctly.
- Check cables, hoses and lines for tears and leaks.
- Check the engine oil level.
- Check the oil level in the steering and hydrostatic fan drive.
- Check the coolant level and correct it, if necessary.
- Check the AdBlue<sup>®</sup>/DEF level (not for EU Stage IIIA).
- Check the fuel level.
- Start the engine and leave it running at medium engine speeds until it is at operating temperature (coolant temperature). While doing so, observe the indicators for oil pressure, coolant temperature and oil temperature.
- Vehicles with auxiliary heating: activate the auxiliary heating and check operation.
- Check operation of the steering and brakes.
- Check whether maintenance is due and if necessary carry it out.

### Decommissioning for longer than 6 months

If the vehicle is to be decommissioned for longer than 6 months, further measures are required. For more details, consult your MTU or MTU-

<sup>2</sup> Further information can be obtained from any Mercedes-Benz Service Centre

authorised Mercedes-Benz Service Centre  
(▷ page 8).



## Important safety notes

### WARNING

If you do not have the prescribed service/maintenance work or necessary repairs carried out, this could result in malfunctions or system failures. There is a risk of an accident. Always have the prescribed service/maintenance work as well as necessary repairs carried out at a qualified specialist workshop.

### WARNING

There are moving components in the engine compartment. Certain components may continue to move or suddenly move again even after the ignition has been switched off, e.g. the radiator fan. There is a risk of injury.

If you have to carry out work in the engine compartment:

- switch off the ignition
- never touch the dangerous areas surrounding moving components, e.g. the rotation area of the fan
- remove jewellery and watches
- keep items of clothing and hair, for example, away from moving parts.

### WARNING

Limbs could be crushed or trapped if the engine is started unintentionally during service or maintenance work. There is a risk of injury.

Always secure the engine against unintentional starting before carrying out maintenance or repair work.

### WARNING

Certain engine components can become very hot. There is a risk of injury when carrying out work at the engine.

Where possible, allow the engine to cool down and only touch the components described below.

When working on the vehicle, always comply with all safety regulations, such as operating instructions, regulations concerning hazardous materials, environmental protection measures, work safety and accident prevention regulations.

Be aware of the road and traffic situation when working on public roads and secure your position accordingly.

Apart from careful operation and maintenance of the engine it is also important that malfunctions be rectified in good time.

You can rectify certain malfunctions yourself, (> page 55).

Have malfunctions that you cannot eliminate yourself rectified at a qualified specialist workshop.

## External engine start/engine stop button

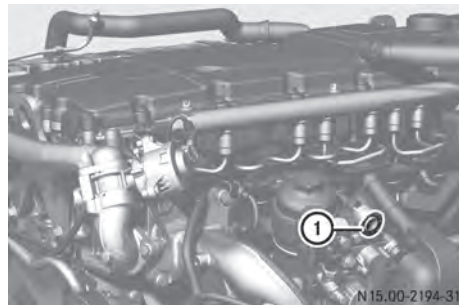

You can start and switch off the engine using the external engine start/engine stop button.

### Before starting the engine

- ▶ Turn the key to the drive position in the ignition lock.
- ▶ Shift into neutral.
- ▶ Secure the vehicle against rolling away.
- ▶ Deactivate power take-off.

### Starting the engine

- ▶ Press external engine start/engine stop button  until the engine starts.

**Starting the engine and increasing the engine speed**

- ▶ Hold down external engine start/engine stop button ① until the desired engine speed is achieved.  
The engine starts and runs at engine idling speed.  
After about 3 seconds, the engine speed increases. After releasing external engine start/engine stop button ①, the engine continues to run at the currently set speed.  
The engine speed can be increased up to the limiting speed.
- ▶ **If the engine does not start immediately:** interrupt the starting procedure after no more than 30 seconds.
- ▶ Repeat the starting procedure after a waiting period of approximately 1 minute.
- ▶ If the engine fails to start: rectify the cause of the poor starting characteristics (▷ page 55).
- ▶ Observe the oil pressure gauge immediately after having started the engine.

**Stopping the engine**

- ▶ Press external engine start/engine stop button ① again.
- ⓘ When the engine is switched off (not for EU Stage IIIA), the system may continue to run for a short while. Depending on the installation position, operating state and ambient temperature, circulation of AdBlue®/DEF is necessary for ensuring cooling. To do this the AdBlue®/DEF delivery pump is actuated during this period.

**Bleeding and draining the fuel system**

Bleeding, after refuelling a fuel system which has been run dry, is performed the next time the engine is started. Automatic continuous bleeding takes place in the filter.

When the engine is started, the battery must have sufficient charge to bleed the fuel system. Bleed the heated fuel prefilter with water separator on the vehicle before the fuel circuit on the engine is bled by the starter motor. Use the manual fuel pump integrated in the fuel prefilter to do so.

**Bleeding the fuel system without a fuel prefilter on the chassis frame**

- ▶ Turn the key to the start position in the ignition lock and hold it. Do not depress the accelerator pedal whilst doing so.
- ⓘ The starting procedure is automatically cancelled after approximately 60 seconds.
- ▶ Repeat the starting procedure after a waiting period of approximately 1 minute.
- ▶ If the engine starts normally, depress the accelerator pedal several times.  
The fuel system is completely bled.

**Bleeding the fuel system with a fuel prefilter on the chassis frame****Ⓢ Environmental note**

Dispose of the water-fuel mixture in an environmentally responsible manner.

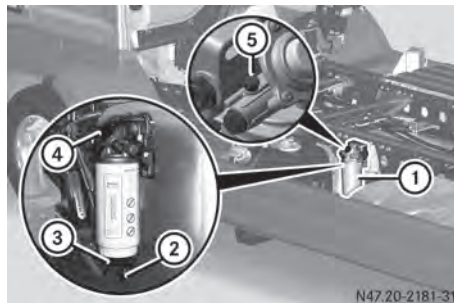

Example: fuel prefilter on the chassis frame

If water has collected in inspection window ③, drain fuel prefilter on chassis frame ① before bleeding. Drain fuel prefilter on chassis frame ① regularly.

**Draining the fuel prefilter on the chassis frame**

- ▶ Place a collector under drain plug ②.
- ▶ Turn drain plug ② open.
- ▶ Press manual fuel pump ④ and collect the fuel/water mixture.
- ▶ Turn drain plug ② closed.

### Bleeding using the manual fuel pump of the fuel prefilter on the chassis frame

- ▶ Unscrew the fuel tank filler cap.
- ▶ Place the collector underneath fuel prefilter ①.
- ▶ Unscrew bleed screw ⑤.
- ▶ Press manual fuel pump ④ repeatedly until the fuel escaping at bleed screw ⑤ is free of bubbles.
- ▶ Tighten bleed screw ⑤.
- i** If there was no fuel in the fuel tank, press manual fuel pump ④ again until there is noticeable resistance.
- i** Then bleed the fuel circuit on the engine as described under "Bleeding the fuel system without a fuel prefilter on the chassis frame".
- ▶ Tighten the fuel tank filler cap.
- ▶ Turn the key to the start position in the ignition lock and hold it. Do not depress the accelerator pedal whilst doing so.
- i** The starting procedure is automatically cancelled after approximately 60 seconds.
- ▶ Repeat the starting procedure after a waiting period of approximately 1 minute.
- ▶ If the engine starts normally, depress the accelerator pedal several times. The fuel system is completely bled.

### Electrical fuses

#### Important safety notes

##### WARNING

If you manipulate, bridge or replace a faulty fuse with a fuse of a higher amperage, the electric cables could be overloaded. This may result in a fire. There is a risk of an accident and injury.

Always replace faulty fuses with specified new fuses of the correct amperage.

The individual electrical circuits are protected by safety fuses or automatic circuit-breakers. Blown fuses or defective automatic circuit-breakers must be replaced by equivalent fuses with the fuse ratings recommended in the fuse allocation chart. Fuses with the same fuse rating are the same colour.

Further information is available from any MTU or MTU-authorized Mercedes-Benz Service Centre (> page 8).

The vehicle-specific fuse allocation chart is provided by the vehicle manufacturer.

If the newly inserted fuse also blows, have the cause traced and rectified at a qualified specialist workshop, e.g. a Mercedes-Benz Service Centre.

- ▶ If a circuit fails, switch off the consumer equipment and switch the ignition lock to position 0.

#### Checking and replacing a safety fuse

- ▶ Pull the fuse out of the module using the pliers and carry out a visual inspection.
- ▶ If the fuse wire has melted, replace the blown fuse with a spare fuse.
- ▶ Switch on consumers and check that they function correctly.

If the safety fuse burns out again, have the electrical system checked at a qualified specialist workshop.

### Jump-starting

#### Important safety notes

##### WARNING

Comply with safety precautions and take protective measures when handling batteries.



Risk of explosion



Fire, naked flames and smoking are prohibited when handling the battery. Avoid creating sparks.



Battery acid is caustic. Avoid contact with the skin, eyes or clothing.

Wear suitable protective clothing, in particular gloves, an apron and a face mask.

Immediately rinse acid splashes off with clean water. Consult a doctor if necessary.



Wear eye protection.



Keep children away.



Observe this Owner's Manual.

**!** Only perform the jump-starting procedure when the engine and catalytic converter are cold. Otherwise, the gas system or the catalytic converter could be damaged.

**!** Observe the following notes. You could otherwise damage the battery or electronic components in the vehicle:

- do not use a battery quick-charge unit for jump-starting.
- if you use a mobile battery charger (battery device with mains power stage), remove the mains plug before jump-starting.
- only have jump-starting provided by vehicles with a 24 V system.
- use jump leads which are protected against polarity reversal and with a wire cross section of approximately 35–50 mm<sup>2</sup> and insulated terminal clamps.
- if the outside temperature drops below -10 °C, a discharged battery could freeze. Do not start the engine under these circumstances. Let the battery thaw out first.

**!** Do not connect the negative terminal clamp of the jump lead to the chassis frame. Otherwise, engine or transmission components can be damaged.

**!** When you remove the jump leads, let the engine of the vehicle being jump-started idle. This avoids damage being caused to the vehicle electronics.

### General notes

Observe the instructions relevant to safety and protective measures when handling the battery. After jump-starting, have the batteries checked at a qualified specialist workshop.

- ▶ Make sure that the vehicles are not touching.
- ▶ Engage the parking brake.
- ▶ Switch off all electrical consumers.
- ▶ Turn the key to position **0** in the ignition lock.

### Vehicles without a jump-starting connection point

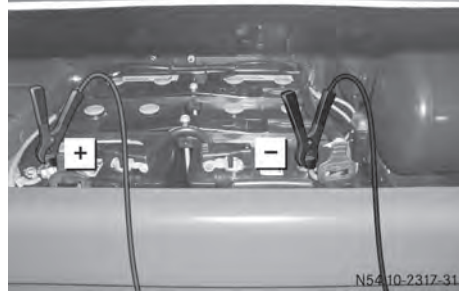

### Connecting the jump lead

- ▶ Remove the battery compartment cover.
- ▶ First, connect the positive terminal clamp of the jump lead to the positive terminal of the other vehicle's battery and then to the **+** positive terminal of the starter battery.
- ▶ First, connect the negative terminal clamp of the jump lead to the negative terminal of the other vehicle's battery and then to the **-** negative terminal of the starter battery.
- ▶ Assisting vehicle: run the engine at a high speed.
- ▶ Start the engine and allow it to idle.

### Disconnecting the jump lead

- ▶ First, disconnect the negative terminal clamps of the jump lead from the negative terminals.
- ▶ Remove the positive terminal clamps of the jump lead from the positive terminals.



**Troubleshooting**

**Engine problems**

 **WARNING**

If you do not have the prescribed service/maintenance work or necessary repairs carried out, this could result in malfunctions or system failures. There is a risk of an accident.

Always have the prescribed service/maintenance work as well as necessary repairs carried out at a qualified specialist workshop.

Apart from careful operation and maintenance of the engine it is also important that malfunctions be rectified in good time. You can rectify certain faults yourself.

Have malfunctions that you cannot eliminate yourself rectified at a qualified specialist workshop (▷ page 8).

Problem	Possible causes/consequences and ► Solutions
The drive pinion does not turn or turns too slowly.	The battery is not sufficiently charged. ► Charge the battery.
	The connecting cable to the starter motor is loose. ► Tighten the cable on the terminal. If necessary, solder on a new terminal.
	The earth connection to the battery is loose. ► Tighten the cable on the terminal. If necessary, solder on a new terminal.
	The starter motor solenoid switch is faulty or the starter motor is faulty. ► Have it checked at a qualified specialist workshop.
The engine does not start or stalls again immediately.	The fuel tank is empty. ► Refill the fuel tank (▷ page 37).
	The fuel filter is blocked. ► Replace the fuel filter element.
	The fuel prefilter contains water. ► Drain the fuel prefilter.
	The fuel prefilter is blocked. ► Replace the fuel filter element.
	There are leaks or there is insufficient pressure in the low-pressure fuel circuit. ► Check for leaks (visual check), replace the seals if necessary. ► Have the fuel pressure tested at a qualified specialist workshop. Replace the seals.



Problem	Possible causes/consequences and ► Solutions
Engine fails to start when the ambient temperature is low.	<p>The fuel is not resistant to cold.</p> <p>The flow properties of the diesel fuel are inadequate due to paraffin separation.</p> <ul style="list-style-type: none"> <li>► Malfunctions resulting from paraffin separation can be corrected by warming the entire fuel system, e.g. by parking the vehicle in a heated area.</li> <li>► Refuel with winter fuel (▷ page 45).</li> </ul>
	<p>The engine oil viscosity is incorrect.</p> <ul style="list-style-type: none"> <li>► Alter the engine oil viscosity to the conditions of use (▷ page 42).</li> <li>► If the engine does not start after another attempt, have the cause traced and rectified at a qualified specialist workshop.</li> </ul>
The engine stops inadvertently.	<p>The power supply to the engine management (MCM) or the exhaust gas aftertreatment (ACM) (not for EU Stage IIIA) control modules is interrupted or there is a short circuit in the wiring.</p> <ul style="list-style-type: none"> <li>► Check the electrical fuses</li> <li>► Have the power supply checked at a qualified specialist workshop.</li> </ul>
	<p>There are leaks or there is insufficient pressure in the low-pressure fuel circuit.</p> <ul style="list-style-type: none"> <li>► Carry out a check for leaks (visual check).</li> <li>► Have the fuel pressure tested at a qualified specialist workshop.</li> </ul>
The engine is in emergency running mode.	<p>There is an interruption in the engine management (NGT) control cluster data flow.</p> <ul style="list-style-type: none"> <li>► Check the battery terminals on the battery and the connectors on the control units for secure seating and corrosion.</li> <li>► Read out the control unit's fault memory.</li> <li>► Have it checked at a qualified specialist workshop.</li> </ul>
The engine surges, vibrates or runs irregularly.	<p>There is a malfunction in the gas system.</p> <ul style="list-style-type: none"> <li>► Carry out a check for leaks (visual check).</li> <li>► Read out the control unit's fault memory.</li> <li>► Have it checked at a qualified specialist workshop.</li> </ul>
The engine's output is poor (lack of power).	<p>The air filter is dirty or blocked.</p> <ul style="list-style-type: none"> <li>► Replace the air filter element.</li> </ul>
	<p>The charge-air temperature is too high; the exterior of the charge-air cooler or engine radiator is dirty.</p> <ul style="list-style-type: none"> <li>► Clean the exterior of the charge-air cooler and engine radiator.</li> </ul>
	<p>The coolant temperature is too high.</p> <ul style="list-style-type: none"> <li>► Check the temperature sensor; replace if necessary. Check the fan speed.</li> <li>► Check the thermostat and replace as necessary. Consult a qualified specialist workshop.</li> </ul>

Problem	Possible causes/consequences and ► Solutions
	<p>Malfunction in the fuel system (blocked, leaking).</p> <ul style="list-style-type: none"> <li>► Visual inspection for leaks.</li> <li>► Consult a qualified specialist workshop.</li> </ul> <p>Poor fuel grade</p> <ul style="list-style-type: none"> <li>► Use the specified type of fuel and fuel grade (► page 44).</li> </ul> <p>The charge-air system is leaking; the hose clip on the charge-air hose is loose or damaged.</p> <ul style="list-style-type: none"> <li>► Check the charge-air system for leaks.</li> <li>► Check the charge-air pressure sensor and, if necessary, replace.</li> <li>► Consult a qualified specialist workshop.</li> </ul> <p>An operating restriction is activated due to an emissions-relevant malfunction (not for EU Stage IIIA).</p> <ul style="list-style-type: none"> <li>► Observe the notes on warning and indicator lamps (► page 29).</li> </ul>
<p>There is an interruption in the tractive power.</p>	<p>There is an increased voltage drop to the engine management (MCM) and exhaust gas aftertreatment (ACM) control modules (loose contact).</p> <ul style="list-style-type: none"> <li>► Check the battery terminals on the battery and the connectors on the engine management (MCM) and exhaust gas aftertreatment (ACM) control modules for secure seating and corrosion.</li> </ul>
<p>The engine braking effect is poor.</p>	<p>The cause must be established in a qualified specialist workshop.</p> <ul style="list-style-type: none"> <li>► Consult a qualified specialist workshop.</li> </ul>
<p>Fuel consumption is too high.</p>	<p>The cause must be established in a qualified specialist workshop.</p> <ul style="list-style-type: none"> <li>► Consult a qualified specialist workshop.</li> </ul>
<p>The engine gets too hot (according to the coolant temperature gauge).</p>	<p>There is not enough coolant in the coolant circuit.</p> <ul style="list-style-type: none"> <li>► Add coolant and bleed the system.</li> </ul> <p>The coolant temperature sensor or display is faulty.</p> <ul style="list-style-type: none"> <li>► Replace the sensor or display.</li> </ul> <p>The poly-V-belt is damaged.</p> <ul style="list-style-type: none"> <li>► Replace the poly-V-belt.</li> </ul> <p>The fan does not switch on correctly.</p> <ul style="list-style-type: none"> <li>► Consult a qualified specialist workshop.</li> </ul> <p>The engine radiator is dirty on the inside; the engine radiator is very dirty on the outside.</p> <ul style="list-style-type: none"> <li>► Clean the engine radiator.</li> </ul> <p>The thermostat is faulty.</p> <ul style="list-style-type: none"> <li>► Check and replace as necessary.</li> <li>► Consult a qualified specialist workshop.</li> </ul>

Problem	Possible causes/consequences and ► Solutions
Indicator lamps do not light up at IGNITION ON.	The lamps are faulty or the electrical cables are interrupted. ► Consult a qualified specialist workshop.
The charge current indicator lamp lights up when the engine is running.	The poly-V-belt is slipping. ► Check the belt tensioner function. ► Check that the poly-V-belt contact surfaces are not torn, damaged, oily or glazed. Replace the poly-V-belt if necessary.
	The poly-V-belt is torn. ► Replace the poly-V-belt.
	The alternator or sensor is faulty. ► Check the alternator or sensor. ► Consult a qualified specialist workshop.
The engine is "knocking".	The engine is misfiring. ► Consult a qualified specialist workshop.
The engine is "knocking".	There is bearing damage. ► Consult a qualified specialist workshop.
There are abnormal sounds.	The air intake pipe and exhaust gas pipe are leaking, causing a whistling noise. ► Rectify the cause of the leak and, if necessary, replace gaskets.
	The turbine or compressor wheel is scraping the housing; there are foreign objects in the compressor or turbine housing; bearings have seized on the rotating parts. ► Have the exhaust gas turbocharger checked at a qualified specialist workshop.
	The valve clearance is excessive. ► Check and adjust the valve clearance.
	The poly-V-belt is slipping. ► Check that the poly-V-belt contact surfaces are not torn, damaged, oily or glazed. Replace the poly-V-belt if necessary.

### Replacing the poly-V-belt

If the poly-V-belt is torn or shows patterns of damage, it must be replaced.

#### WARNING

The tensioning device is spring-tensioned. When it is loosened or tightened, there is a risk of injury from crushing or entrapment in pretensioned parts.

- Always carry out work on the tensioning device with extreme care.
- Make sure that the tool is handled correctly.

**Belt profile**

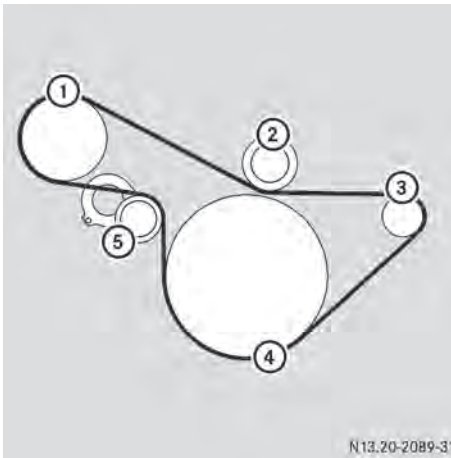

N13.20-2089-31

Poly-V-belt routing (engine without refrigerant compressor)

- ① Coolant pump
- ② Guide pulley
- ③ Alternator
- ④ Crankshaft
- ⑤ Tensioning pulley

- ⑥ Crankshaft
- ⑦ Tensioning pulley

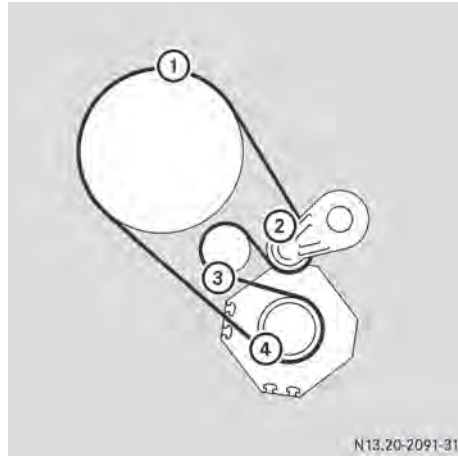

N13.20-2091-31

Poly-V-belt routing (engine with cooling system)

- ① Crankshaft
- ② Tensioning pulley
- ③ Guide pulley
- ④ Cooling system generator

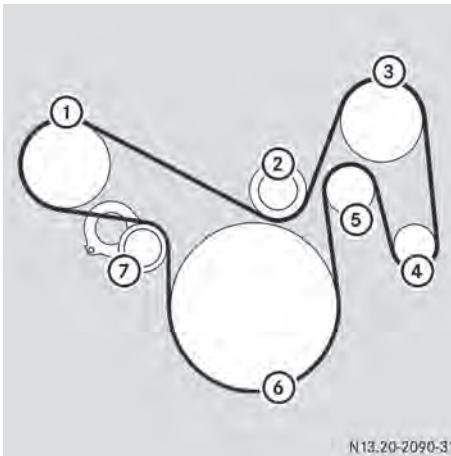

N13.20-2090-31

Poly-V-belt routing (engine with refrigerant compressor)

- ① Coolant pump
- ② Guide pulley
- ③ Refrigerant compressor
- ④ Alternator
- ⑤ Guide pulley

**Fitting/removing poly-V-belts**

- ▶ Insert the spanner, with the handle and extension attached, 15 mm into the tensioner.
- ▶ Swing back the tensioner.
- ▶ Check that both the tensioner and the belt pulley are in fault-free condition. Check for such defects as worn bearings in the tensioner, tensioning pulley and guide pulleys and for wear of the tooth profile on the belt pulleys.
- ▶ Replace faulty parts.
- ▶ Route the new poly-V-belt over all belt pulleys except the tensioning pulley (observe the poly-V-belt routing shown in the illustration).
- ▶ Remove the spanner and check for correct seating of the poly-V-belt on the belt pulleys.

## Identification plates

### Engine data plate

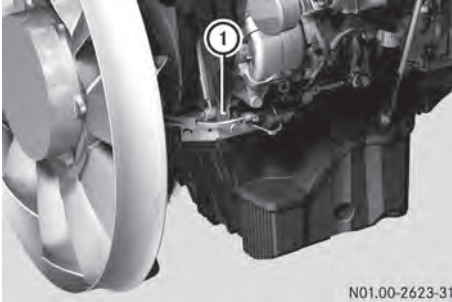

- ① Position of engine data plate (example)

### Information on the engine data plate

The following data is contained on the engine data plate in the form of numbers stamped directly onto the crankcase:

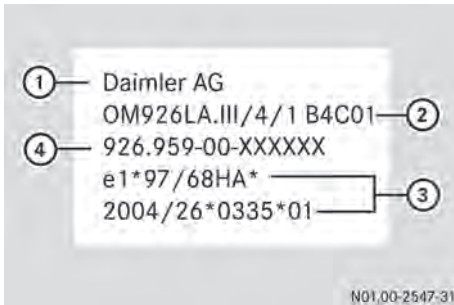

Example: engine data plate

- ① Manufacturer's name
- ② Engine model designation
- ③ Type approval number
- ④ Engine number

### Emission certification label

In engines with the US TIER 4 emissions certificate, the emission certification label (EPA Certification) is located on the cylinder head cover.

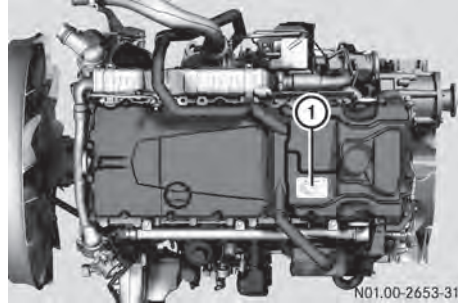

- ① Position Emission certification label (EPA Certification)

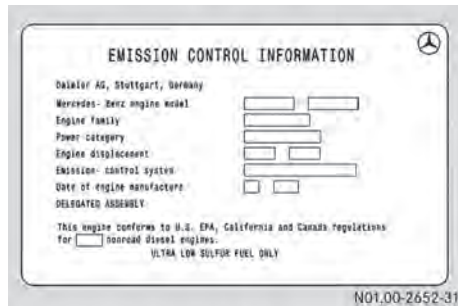

### Exhaust gas aftertreatment identification plate (not for EU Stage IIIA)

The exhaust gas aftertreatment identification plate is located on the exhaust gas aftertreatment control module (ACM).

### Information on the exhaust gas aftertreatment identification plate

The identification plate for the exhaust gas aftertreatment unit contains the 14-digit identification number (AGN ID number) of the exhaust gas aftertreatment unit.

## Data card

The data card forms an integral part of the documents belonging to the engine and should always be kept with the Maintenance Booklet. It contains details about the design of the engine and the exhaust gas aftertreatment system, including special features.

Conversion parts on the engine system which change the scope of the engine delivered by Mercedes-Benz should be reported to Mercedes-Benz. Once the documentation has been updated in VeDoc, an updated data card is supplied. This helps to prevent incorrect ordering of replacement parts.

The following is absolutely necessary when procuring genuine Mercedes-Benz parts:

- the data card or
- the complete engine number and the number of the exhaust gas aftertreatment unit.

### Engine data

#### Dimensions and weights

All data refers to the standard version of the respective engine type. Deviations may occur, depending on the engine equipment and installation situation in the vehicle/device.

#### Dimensions

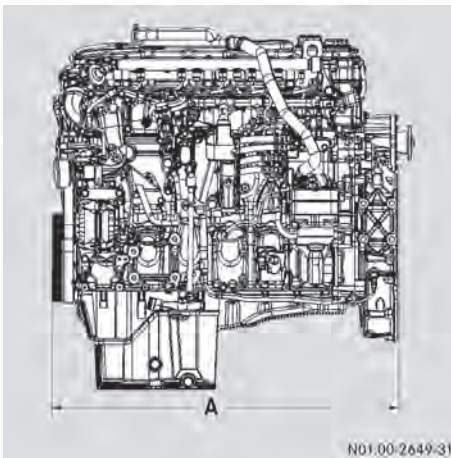

Example: engine length

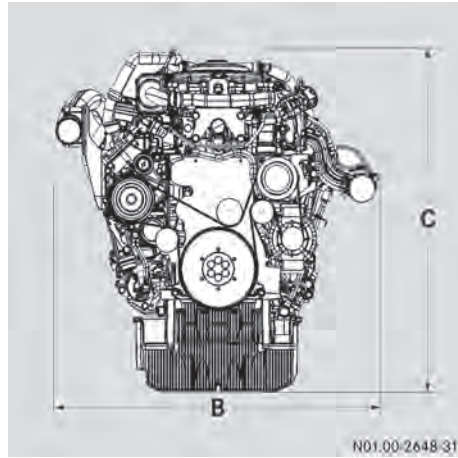

Example: engine width and height

	R4 1000	R6 1000
A = engine length with fan	948 mm	1059 mm
B = engine width	817 mm	924 mm
C = engine height	1033 mm	1068 mm

#### Weights

Engine weight DIN 70020 - GZ

	4R 1000	6R 1000
Single-stage charging	499 kg	655 kg
Dual-stage charging	510 kg	669 kg

#### General data

All data refers to the standard version of the respective engine type. Data for other versions is available on request.

Engine	Engine type	4R 1000	6R 1000
	Assembly model series	933.91	935.91

	Type	In-line engine with exhaust gas recirculation and charge-air pressure control	
	Combustion principle	4-stroke direct injection diesel	
	Number of cylinders	4	6
	Bore	110 mm	110 mm
	Stroke	135 mm	135 mm
	Engine capacity	5130 cm <sup>3</sup>	7700 cm <sup>3</sup>
	Firing order	1 -3 -4 -2	1 - 5 - 3 - 6 - 2 - 4
	Type of cooling system	Forced circulation cooling	
	Engine, direction of rotation	Anti-clockwise (when looking at the flywheel)	
Valve clearance	Intake valve	0.30 mm +/- 0.05 mm	0.30 mm +/- 0.05 mm
	Exhaust valve	0.60 mm +/- 0.1 mm	0.60 mm +/- 0.1 mm
	Engine brake when using adjusting gauges (0.6 mm) on both exhaust valves	0.15 mm	0.15 mm
Starter motor	Starter	Electric	Electric
	Voltage	24 V	24 V
	Output	3.9 kW	3.9 kW
	Cold-start limit	-30 °C (battery capacity 75 %)	
Alternator	Voltage	24 V	24 V
	Amperage	100 A	100 A

### Operating data

Operating range of engine brake		Approx. 1000 - 3000 rpm
Engine speed range of maximum engine torque		Approx. 1200 - 1600 rpm
Engine speed of maximum power output		Approx. 2200 rpm
Idling speed		Approx. 600 rpm
Oil pressure at idling speed		Minimum 0.5 bar
Coolant temperature	Normal operation	Approx. 85 - 100 °C
	Maximum permissible temperature of coolant (automatic torque limitation up to 50 % from 103 °C)	105 °C



**Capacities and service products**

		Capacity approx- imately	Service product (Sheet No. <sup>3</sup> )	
Engine with oil filter (with standard truck oil pan)	4R 1000	17.5 l - 20.5 l	Engine oil (Sheet No. 228.3/.31/.5/.51)	
	6R 1000	24.5 l - 29.5 l		
Fuel system	Fuel tank <sup>4</sup>		Diesel fuels in accord- ance with DIN EN 590 as of 2010 ff or ASTM D975 (Sheet No. 131.0)	
Exhaust gas aftertreat- ment sys- tem <sup>5</sup>	AdBlue <sup>®</sup> /DEF tank <sup>4</sup>		AdBlue <sup>®</sup> /DEF in accord- ance with ISO 22241 -1 (Sheet No. 352.1)	
	AdBlue <sup>®</sup> /DEF filter sealing rings	-	MB silicon grease	
Cooling sys- tem	Amount of cool- ant in the engine	4R 1000	Approx. 11 l	Corrosion inhibitor/anti- freeze (Sheet No. 325.5) or premixed coolant (Sheet No. 326.5). Water quality (Sheet No. 310.1)
		6R 1000	Approx. 14 l	
	Corrosion inhibitor/antifreeze agent volume down to - 37 °C	Approx. 50% by volume		
Corrosion inhibitor/antifreeze agent volume down to - 45 °C	Max. 55% by volume			
Engine com- partment	Protective wax	-	Wax preservative (Sheet No. 385.4)	

Technical data

**Tightening torques**

All threads on mechanical components and the corresponding contact surfaces must be clean, smooth and coated with engine oil. Other lubricants lead to substantially different tightening torques.

The tightening torques are the same for 4R 1000 and 6R 1000.

Engine	Cylinder head cover screw on the rocker arm frame (observe the tightening sequence for the cylinder head cover)	Light alloy	20 Nm
		Thermoplastic	25 Nm
	Valve clearance setting	Counternut on the rocker arm adjustment screw	30 Nm
	Engine brake setting	Counternut on the rocker arm adjustment screw	27 Nm
	Screw of TDC inspection hole cap on the flywheel housing		30 Nm

<sup>3</sup> Mercedes-Benz Specifications for Service Products

<sup>4</sup> Installation on the vehicle. Designed by the vehicle manufacturer.

<sup>5</sup> Not for EU Stage IIIA.

	Cranking device screw on the timing case	30 Nm
Fuel system	Fuel filter cap on the fuel filter module	25 Nm
	Fuel prefilter cap on the fuel filter module	25 Nm
Oil circuit	Drain plug on the oil pan (thermoplastic and light alloy) M16 x 1.5	35 Nm
	Oil filter cap on the oil/coolant module	50 Nm
Cooling system	Silicate gel cartridge on the coolant pump	50 Nm
Exhaust gas aftertreatment <sup>6</sup>	Filter housing on the pump module	80 Nm
Air dryer	Granulate cartridge on the air dryer	15 Nm

### Tightening sequence for the cylinder head cover

The cylinder head cover screws must be tightened in the correct tightening sequence in the same order as described below.

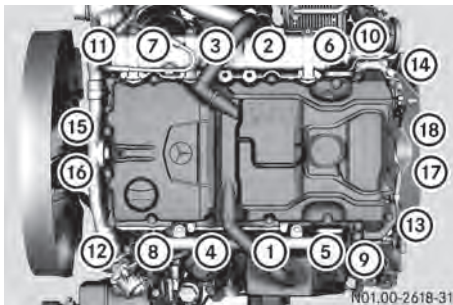

Tightening sequence for 4R 1000

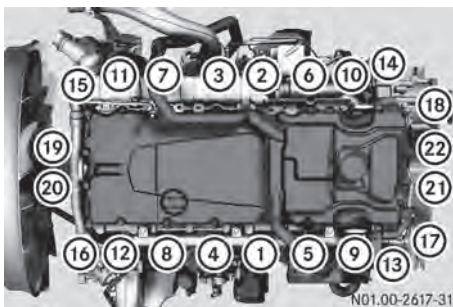

Tightening sequence for 6R 1000

<sup>6</sup> Not for EU Stage IIIA

## **Publication details**

### **Internet**

Further information about MTU, Mercedes-Benz and Daimler AG can be found online at:

[www.mtu-online.com](http://www.mtu-online.com)

[www.mercedes-benz.com](http://www.mercedes-benz.com)

[www.daimler.com](http://www.daimler.com)

### **Documentation team**

Should you have any questions or suggestions regarding this manual, you can reach the technical documentation team at the following address:

Daimler AG, HPC: CAC, Customer Service,  
70546 Stuttgart, Germany

©Daimler AG: not to be reprinted, translated or otherwise reproduced, in whole or in part, without written permission from Daimler AG.

### **Assembly manufacturer**

Daimler AG  
Mercedesstraße 137  
70327 Stuttgart  
Germany



9345842081

Order no. 6462 9886 02 Part no. 934 584 20 81 Edition 07-16