

GAS ENGINE-GENERATOR SET

AIR CHARGE-AIR COOLING

400 kWe / 60 Hz / Standby
208 - 600V

(Reference GP355N6S for Prime Rating Technical Data)



SYSTEM RATINGS

Standby (NG) (LP)	GS400N6SGA GS400L6SGA	GS400N6SPA GS400L6SPA	GS400N6SJA GS400L6SJA	GS400N6SRA GS400L6SRA	GS400N6SNA GS400L6SNA
Voltage (L-L)	240V**	208V**	240V**	480V**	600V**
Phase	1	3	3	3	3
PF	1.0	0.8	0.8	0.8	0.8
Hz	60	60	60	60	60
Natural Gas Ratings: Amps	1604	1388	1203	601	481
Natural Gas Ratings: kW/kVA	385/385	400/500	400/500	400/500	400/500
LP Gas Ratings: Amps	1187	1023	887	443	355
LP Gas Ratings: kW/kVA	285/285	295/368	295/368	295/368	295/368
skVA@30%					
Voltage Dip	760	1500	1500	1500	1080
Generator Model*	574RSL4037	572RSL4029	572RSL4029	572RSL4029	433RSS4266
Temp Rise	130 °C/40 °C	130 °C/40 °C	130 °C/40 °C	130 °C/40 °C	130 °C/40 °C
Connection	12 LEAD ZIG-ZAG	12 LEAD LOW WYE	12 LEAD HI DELTA	12 LEAD HI WYE	4 LEAD WYE

* The Generator Model Number identified in the table is for standard C Series Configuration. Consult the factory for alternate configuration.

** UL 2200 Offered

CERTIFICATIONS AND STANDARDS

// **Engine-generator set is designed and manufactured in facilities certified to standards ISO 9001:2008 and ISO 14001:2004**

// **Power Rating**

- Accepts Rated Load in One Step Per NFPA 110

// **UL 2200 / CSA – Optional**

- UL 2200 Listed
- CSA Certified

// **Performance Assurance Certification (PAC)**

- Engine-Generator Set Tested to ISO 8528-5 for Transient Response
- Verified product design, quality and performance integrity
- All engine systems are prototype and factory tested

STANDARD FEATURES*

- // MTU Onsite Energy is a single source supplier
- // Global Product Support
- // 2 Year Standard Warranty
- // 21.9 L Turbo Engine Charge Air Cooling
 - 21.9 Liter Displacement
 - 4-Cycle
- // 3-Way Catalyst
- // Optional Fuels: LP Liquid and Dual Fuel
- // Engine-generator resilient mounted
- // Complete Range of Accessories

- // Generator
 - Brushless, Rotating Field Generator
 - PMG (Permanent Magnet Generator) supply to regulator
 - 300% Short Circuit Capability
 - 2/3 Pitch Windings
 - Standard for 570 frame and larger
 - Optional for 430 frame and smaller
- // Digital Control Panel(s)
 - UL Recognized, CSA Certified, NFPA 110
 - Complete System Metering
 - LCD Display
- // Cooling System
 - Integral Set-Mounted
 - Engine Driven Fan

STANDARD EQUIPMENT*

// Engine

Air Cleaner
 Oil Pump
 Oil Drain Extension & S/O Valve
 Full Flow Oil Filter
 Jacket Water Pump
 Thermostats
 Blower Fan & Fan Drive
 Radiator - Unit Mounted
 Electric Starting Motor - 24V
 Governor - Electronic Isochronous
 Base - Formed Steel
 SAE Flywheel & Bell Housing
 Charging Alternator - 24V
 Battery Box & Cables
 Flexible Fuel Connectors
 Flexible Exhaust Connection
 EPA Certified Engine

// Generator

NEMA MG1, IEEE and ANSI standards compliance for temperature rise and motor starting
 Sustained short circuit current of up to 300% of the rated current for up to 10 seconds
 Self Ventilated and Drip-proof
 Superior Voltage Waveform
 Digital, Solid State, Volts-per-hertz Regulator
 No load to full load regulation

Brushless Alternator with Brushless Pilot Exciter
 4 pole, Rotating Field
 130 °C Maximum Standby Temperature Rise
 1 Bearing, Sealed
 Flexible Coupling
 Full Amortisseur Windings
 125% Rotor Balancing
 3-phase Voltage Sensing
 ±1% Voltage Regulation
 100% of Rated Load - One Step
 3% Maximum Harmonic Content

// Digital Control Panel(s)

Digital Metering
 Engine Parameters
 Generator Protection Functions
 Engine Protection
 SAE J1939 Engine ECU Communications
 Windows-based Software
 Multilingual Capability
 Remote Communications to RDP-110 Remote Annunciator
 16 Programmable Contact Inputs
 Up to 11 Contact Outputs
 UL Recognized, CSA Certified, CE Approved
 Event Recording
 IP 54 Front Panel Rating with Integrated Gasket
 NFPA110 Compatible

* Represents standard product only. Consult Factory/MTU Onsite Energy Distributor for additional configurations.

APPLICATION DATA

// Engine

Manufacturer	Doosan
Model	21.9L CAC
Type	4-Cycle
Arrangement	12-V
Displacement: L (in ³)	21.9 (1,338)
Bore: cm (in)	12.8 (5.04)
Stroke: cm (in)	14.2 (5.59)
Compression Ratio	10.5:1
Rated RPM	1,800
Engine Governor	Bosch
Maximum Power (NG): kWm (bhp)	456 (612)
Maximum Power (LP): kWm (bhp)	351 (471)
Speed Regulation	±0.5%
Air Cleaner	Dry

// Liquid Capacity (Lubrication)

Total Oil System: L (gal)	47.1 (12.4)
Engine Jacket Water Capacity: L (gal)	52.3 (11.5)
System Coolant Capacity: L (gal)	291 (64)

// Electrical

Electric Volts DC	24
Cold Cranking Amps Under -17.8 °C (0 °F)	1,000

// Fuel Inlet

Fuel Supply Connection Size	3" NPT
Fuel Supply Pressure: mm H ₂ O (in. H ₂ O)	178–279 (7–11)

// Fuel Consumption (NG-1000 BTU/ft³ / LP-2500 BTU/ft³)

	NG	LPG
At 100% of Power Rating: m ³ /hr (ft ³ /hr)	119.8 (4,230)	39.9 (1,407)
At 75% of Power Rating: m ³ /hr (ft ³ /hr)	93.4 (3,297)	34 (1,200)
At 50% of Power Rating: m ³ /hr (ft ³ /hr)	65.5 (2,314)	22.9 (808)

// Cooling - Radiator System

Ambient Capacity of Radiator: °C (°F)	50 (122)*
Maximum Restriction of Cooling Air, Intake, and Discharge Side of Rad.: kPa (in. H ₂ O)	0.12 (0.5)
Water Pump Capacity: L/min (gpm)	660 (174)
Heat Rejection to Coolant: kW (BTUM)	453 (25,760)
Heat Radiated to Ambient: kW (BTUM)	118.2 (6,720)

* Installation of enclosures reduces the ambient capacity of the cooling system by 1 °C (1.8 °F). Gravity exhaust louvers reduce ambient capacity of the cooling system by an additional 3 °C (5.5 °F).

// Air Requirements

Aspirating: *m ³ /min (SCFM)	24.6 (841)
Air Flow Required for Rad.	
Cooled Unit: **m ³ /min (SCFM)	1,133 (40,000)
Remote Cooled Applications; Air Flow Required for Dissipation of Radiated Gen-set Heat for a Max of 25 °F Rise: *m ³ /min (SCFM)	429 (15,160)

* Air density = 1.184 kg/m³ (0.0739 lbm/ft³)

** At 0.25 kPa (1 in. H₂O) static pressure and 52 °C (125 °F) at radiator

// Exhaust System

Gas Temp. (Stack): °C (°F)	582 (1,080)
Gas Volume at Stack Temp: m ³ /min (CFM)	72.2 (2,550)
Maximum Allowable Back Pressure: kPa (in. H ₂ O)	5.1 (20.5)

WEIGHTS AND DIMENSIONS

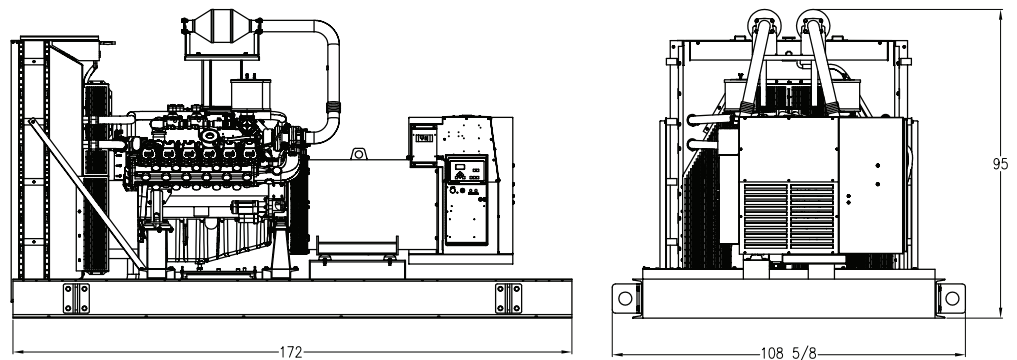

Drawing above for illustration purposes only, based on standard open power 480 volt engine-generator set. Lengths may vary with other voltages. Do not use for installation design. See website for unit specific template drawings.

System

Open Power Unit (OPU)

Dimensions (L x W x H)

4,369 x 2,760 x 2,413 mm (172 x 108.63 x 95 in)

Weight (dry)

5,228 kg (11,500 lb)

Weights and dimensions are based on open power units and are estimates only. Consult the factory for accurate weights and dimensions for your specific engine-generator set.

SOUND DATA

Unit Type

Level 0: Open Power Unit (dBA)

Standby Full Load (NG)

86.2

Standby Full Load (LP)

85.3

Sound data is provided at 7 m (23 ft). Engine-generator set tested in accordance with ISO 8528-10 and with infinite exhaust.

EMISSIONS DATA

Fuel Type

Natural Gas

Liquid Propane

THC + NO_x

0.38

0.06

CO

0.1

0.25

All units are in g/hp-hr and are EPA D2 cycle values.

RATING DEFINITIONS AND CONDITIONS

- // Ambient capability factor at 984 ft (300 m). Consult your local MTU Onsite Energy Power Generation Distributor for other altitudes.
- // Standby ratings apply to installations served by a reliable utility source. The standby rating is applicable to varying loads for the duration of a power outage. No overload capability for this rating. Ratings are in accordance with ISO 3046-1, BS 5514, AS 2789, and DIN 6271.
- // Deration Factor:
Production tolerances in engines and installed components can account for power variations. Altitude, temperature and excessive exhaust and intake restrictions should be applied to power calculations. Consult your local MTU Onsite Energy Power Generation Distributor for derations.

Materials and specifications subject to change without notice.

C/F = Consult Factory/MTU Onsite Energy Distributor