

# DIESEL ENGINE-GENERATOR SET

## AIR CHARGE-AIR COOLING

60 kWe / 60 Hz / Standby  
208 - 600V

(Reference DP51D6S for Prime Rating Technical Data)



### SYSTEM RATINGS

Standby	DS60D6SGA	DS60D6SDA	DS60D6SPA	DS60D6SJA	DS60D6SRA	DS60D6SNA
Voltage (L-L)	240V**	240V**	208V**	240V**	480V**	600V**
Phase	1	1	3	3	3	3
PF	1.0	1.0	0.8	0.8	0.8	0.8
Hz	60	60	60	60	60	60
kW	60	60	60	60	60	60
kVA	60	60	75	75	75	75
AMPS	250	250	208	180	90	72
skVA@30%						
Voltage Dip	119	130	150	150	198	136
Generator Model	362CSL1604	361CSL1613	361CSL1602	361CSL1602	361CSL1602	361PSL1633
Temp Rise	130 °C/40 °C	130 °C/40 °C	130 °C/40 °C	130 °C/40 °C	130 °C/40 °C	130 °C/40 °C
Connection	12 LEAD ZIG-ZAG	4 LEAD	12 LEAD LOW WYE	12 LEAD HI DELTA	12 LEAD HI WYE	4 LEAD WYE

\*\* UL 2200 Offered

### CERTIFICATIONS AND STANDARDS

// Emissions – EPA Tier 3 Certified

// Engine-generator set is designed and manufactured in facilities certified to standards ISO 9001:2008 and ISO 14001:2004

// Seismic Certification – Optional

- IBC Certification
- OSHPD Pre-Approval

// UL 2200 / CSA – Optional

- UL 2200 Listed
- CSA Certified

// Performance Assurance Certification (PAC)

- Engine-Generator Set Tested to ISO 8528-5 for Transient Response
- Verified product design, quality and performance integrity
- All engine systems are prototype and factory tested

// Power Rating

- Accepts Rated Load in One Step Per NFPA 110

## STANDARD FEATURES\*

- // MTU Onsite Energy is a single source supplier
- // Global Product Support
- // 2 Year Standard Warranty
- // 5030HF285 Diesel Engine
  - 3.0 Liter Displacement
  - Electronic Unit Pump Injection
  - 4-Cycle
- // Engine-generator resilient mounted
- // Complete Range of Accessories

- // Generator
  - Brushless, Rotating Field Generator
  - 300% Short Circuit Capability
  - 2/3 Pitch Windings
- // Digital Control Panel(s)
  - UL Recognized, CSA Certified, NFPA 110
  - Complete System Metering
  - LCD Display
- // Cooling System
  - Integral Set-Mounted
  - Engine Driven Fan

## STANDARD EQUIPMENT\*

### // Engine

Air Cleaner  
 Oil Pump  
 Oil Drain Extension & S/O Valve  
 Full Flow Oil Filter  
 Fuel Filter with Water Separator  
 Jacket Water Pump  
 Thermostat  
 Blower Fan & Fan Drive  
 Radiator - Unit Mounted  
 Electric Starting Motor - 12V  
 Governor - Electronic Isochronous  
 Base - Formed Steel  
 SAE Flywheel & Bell Housing  
 Charging Alternator - 12V  
 Battery Box & Cables  
 Flexible Fuel Connectors  
 Flexible Exhaust Connection  
 EPA Certified Engine

### // Generator

NEMA MG1, IEEE and ANSI standards compliance for temperature rise and motor starting  
 Sustained short circuit current of up to 300% of the rated current for up to 10 seconds  
 Self-Ventilated and Drip-Proof  
 Superior Voltage Waveform  
 Digital, Solid State, Volts-per-Hertz Regulator  
 No Load to Full Load Regulation

Brushless Alternator with Brushless Pilot Exciter  
 4 Pole, Rotating Field  
 130 °C Maximum Standby Temperature Rise  
 1 Bearing, Sealed  
 Flexible Coupling  
 Full Amortisseur Windings  
 125% Rotor Balancing  
 3-Phase Voltage Sensing  
 ±1% Voltage Regulation  
 100% of Rated Load - One Step  
 3% Maximum Harmonic Content

### // Digital Control Panel(s)

Digital Metering  
 Engine Parameters  
 Generator Protection Functions  
 Engine Protection  
 SAE J1939 Engine ECU Communications  
 Windows-Based Software  
 Multilingual Capability  
 Remote Communications to RDP-110 Remote Annunciator  
 16 Programmable Contact Inputs  
 Up to 11 Contact Outputs  
 UL Recognized, CSA Certified, CE Approved  
 Event Recording  
 IP 54 Front Panel Rating with Integrated Gasket  
 NFPA110 Compatible

\* Represents standard product only. Consult Factory/MTU Onsite Energy Distributor for additional configurations.

## APPLICATION DATA

### // Engine

Manufacturer	John Deere
Model	5030HF285
Type	4-Cycle
Arrangement	5 In-Line
Displacement: L (in <sup>3</sup> )	3.05 (186)
Bore: cm (in)	8.6 (3.4)
Stroke: cm (in)	10.5 (4.1)
Compression Ratio	18.2:1
Rated RPM	1,800
Engine Governor	JDEC
Maximum Power: kW <sub>m</sub> (bhp)	72 (96)
Speed Regulation	±0.25%
Air Cleaner	Dry

### // Liquid Capacity (Lubrication)

Total Oil System: L (gal)	11.2 (2.96)
Engine Jacket Water Capacity: L (gal)	2.9 (0.78)
System Coolant Capacity: L (gal)	15.4 (4.08)

### // Electrical

Electric Volts DC	12
Cold Cranking Amps Under -17.8 °C (0 °F)	750

### // Fuel System

Fuel Supply Connection Size	3/8" NPT
Fuel Return Connection Size	3/8" NPT
Maximum Fuel Lift: m (ft)	3 (10)
Recommended Fuel	Diesel #2
Total Fuel Flow: L/hr (gal/hr)	82 (21.7)

### // Fuel Consumption

	STANDBY
At 100% of Power Rating: L/hr (gal/hr)	18.9 (5)
At 75% of Power Rating: L/hr (gal/hr)	14.4 (3.8)
At 50% of Power Rating: L/hr (gal/hr)	9.5 (2.5)

### // Cooling - Radiator System

	STANDBY
Ambient Capacity of Radiator: °C (°F)	50 (122)
Maximum Allowable Static Pressure on Rad. Exhaust: kPa (in. H <sub>2</sub> O)	0.12 (0.5)
Water Pump Capacity: L/min (gpm)	100 (26)
Heat Rejection to Coolant: kW (BTUM)	45.5 (2,590)
Heat Rejection to Air to Air: kW (BTUM)	12.7 (723)
Heat Radiated to Ambient: kW (BTUM)	12.8 (728)

### // Air Requirements

	STANDBY
Aspirating: *m <sup>3</sup> /min (SCFM)	5.3 (186)
Air Flow Required for Rad. Cooled Unit: *m <sup>3</sup> /min (SCFM)	158 (5,570)
Remote Cooled Applications; Air Flow Required for Dissipation of Radiated Gen-set Heat for a Max of 25 °F Rise: *m <sup>3</sup> /min (SCFM)	47 (1,642)

\* Air density = 1.184 kg/m<sup>3</sup> (0.0739 lbm/ft<sup>3</sup>)

### // Exhaust System

	STANDBY
Gas Temp. (Stack): °C (°F)	522 (972)
Gas Volume at Stack Temp: m <sup>3</sup> /min (CFM)	13.7 (484)
Maximum Allowable Back Pressure: kPa (in. H <sub>2</sub> O)	7.5 (30)
Minimum Allowable Back Pressure: kPa (in. H <sub>2</sub> O)	4 (16)

## WEIGHTS AND DIMENSIONS

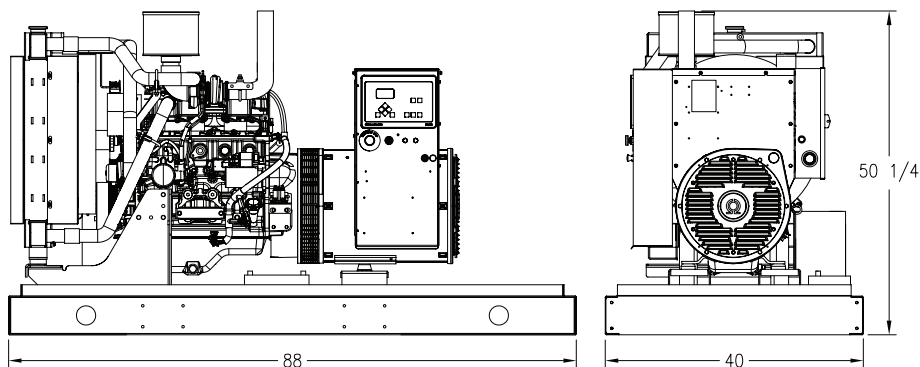

Drawing above for illustration purposes only, based on standard open power 480 volt engine-generator set. Lengths may vary with other voltages. Do not use for installation design. See website for unit specific template drawings.

### System

Open Power Unit (OPU)

### Dimensions (L x W x H)

2,235 x 1,016 x 1,276 mm (88 x 40 x 50.25 in)

### Weight (dry/less tank)

883 kg (1,947 lb)

Weights and dimensions are based on open power units and are estimates only. Consult the factory for accurate weights and dimensions for your specific engine-generator set.

## SOUND DATA

### Unit Type

Level 0: Open Power Unit (dBA)

### Standby Full Load

79.2

Sound data is provided at 7 m (23 ft). Engine-generator set tested in accordance with ISO 8528-10 and with infinite exhaust.

## EMISSIONS DATA

### NO<sub>x</sub> + NMHC

3.4

### CO

0.8

### PM

0.15

### All units are in g/hp-hr and are EPA D2 cycle values.

Emission levels of the engine may vary as a function of ambient temperature, barometric pressure, humidity, fuel type and quality, installation parameters, measuring instrumentation, etc. The data provided are laboratory results from one engine representing this rating. The data was obtained under controlled environmental conditions with calibrated instrumentation traceable to the United States National Bureau of Standards and in compliance with US EPA regulations found within 40 CFR Part 89. The weighted cycle value from each engine is guaranteed to be below the US EPA Standards at the US EPA defined conditions.

## RATING DEFINITIONS AND CONDITIONS

// Standby ratings apply to installations served by a reliable utility source. The standby rating is applicable to varying loads for the duration of a power outage. No overload capability for this rating. Ratings are in accordance with ISO 3046-1, BS 5514, AS 2789, and DIN 6271.

// Deration Factor:

**Altitude:** Consult your local MTU Onsite Energy Power Generation Distributor for altitude derations.

**Temperature:** Consult your local MTU Onsite Energy Power Generation Distributor for temperature derations.

Materials and specifications subject to change without notice.

C/F = Consult Factory/MTU Onsite Energy Distributor