

DIESEL ENGINE-GENERATOR SET

AIR CHARGE-AIR COOLING

400 kWe / 60 Hz / Standby
208 - 600V

(Reference DP365D6S for Prime Rating Technical Data)



SYSTEM RATINGS

Standby	DS400D6SPA	DS400D6SJA	DS400D6SVA	DS400D6SWA	DS400D6SRA	DS400D6SNA
Voltage (L-L)	208V**	240V**	380V	440V	480V**	600V**
Phase	3	3	3	3	3	3
PF	0.8	0.8	0.8	0.8	0.8	0.8
Hz	60	60	60	60	60	60
kW	400	400	400	400	400	400
kVA	500	500	500	500	500	500
AMPS	1388	1203	760	656	601	481
skVA@30%						
Voltage Dip	800	820	640	920	1100	1100
Generator Model	572RSL4025	572RSL4025	572RSL4025	433CSL6220	433CSL6220	433PSL6248
Temp Rise	130 °C/40 °C	130 °C/40 °C	130 °C/40 °C	130 °C/40 °C	130 °C/40 °C	130 °C/40 °C
Connection	12 LEAD LOW WYE	12 LEAD HI DELTA	12 LEAD HI WYE	12 LEAD HI WYE	12 LEAD HI WYE	4 LEAD WYE

** UL 2200 Offered

CERTIFICATIONS AND STANDARDS

// **Emissions** – EPA Tier 3 Certified

// **Engine-generator set is designed and manufactured in facilities certified to standards ISO 9001:2008 and ISO 14001:2004**

// **UL 2200 / CSA – Optional**

- UL 2200 Listed
- CSA Certified

// **Performance Assurance Certification (PAC)**

- Engine-Generator Set Tested to ISO 8528-5 for Transient Response
- Verified product design, quality and performance integrity
- All engine systems are prototype and factory tested

// **Power Rating**

- Accepts Rated Load in One Step Per NFPA 110
- Permissible average power output during 24 hours of operation is approved up to 85%.

STANDARD FEATURES*

- // MTU Onsite Energy is a single source supplier
 - // Global Product Support
 - // 2 Year Standard Warranty
 - // 8V1600 Diesel Engine
 - 14.0 Liter Displacement
 - Common Rail Fuel Injection
 - 4-Cycle
 - // Engine-generator resilient mounted
 - // Complete Range of Accessories
- // Generator
 - Brushless, Rotating Field Generator
 - PMG (Permanent Magnet Generator) supply to regulator (570 frame only)
 - 300% Short Circuit Capability
 - 2/3 Pitch Windings
 - // Digital Control Panel(s)
 - UL Recognized, CSA Certified, NFPA 110
 - Complete System Metering
 - LCD Display
 - // Cooling System
 - Integral Set-Mounted
 - Engine Driven Fan

STANDARD EQUIPMENT*

// Engine

Air Cleaners
 Oil Pump
 Oil Drain Extension & S/O Valve
 Full Flow Oil Filters
 Closed Crankcase Ventilation
 Jacket Water Pump
 Thermostats
 Blower Fan & Fan Drive
 Radiator - Unit Mounted
 Electric Starting Motor - 24V
 Governor - Electronic Isochronous
 Base - Formed Steel
 SAE Flywheel & Bell Housing
 Charging Alternator - 24V
 Battery Box & Cables
 Flexible Fuel Connectors
 Flexible Exhaust Connection
 EPA Certified Engine

// Generator

NEMA MG1, IEEE and ANSI standards compliance for temperature rise and motor starting
 Sustained short circuit current of up to 300% of the rated current for up to 10 seconds
 Self-Ventilated
 Superior Voltage Waveform
 Digital, Solid State, Volts-per-Hertz Regulator
 No Load to Full Load Regulation

Brushless Alternator with Brushless Pilot Exciter
 4 Pole, Rotating Field
 130 °C Maximum Standby Temperature Rise
 1 Bearing, Sealed
 Flexible Coupling
 Full Amortisseur Windings
 125% Rotor Balancing
 3-Phase Voltage Sensing
 ±0.25% Voltage Regulation (570 frame)
 ±1% Voltage Regulation (430 frame)
 100% of Rated Load - One Step
 3% Maximum Harmonic Content

// Digital Control Panel(s)

Digital Metering
 Engine Parameters
 Generator Protection Functions
 Engine Protection
 CAN Bus ECU Communications
 Windows-Based Software
 Multilingual Capability
 Remote Communications to RDP-110 Remote Annunciator
 16 Programmable Contact Inputs
 Up to 11 Contact Outputs
 UL Recognized, CSA Certified, CE Approved
 Event Recording
 IP 54 Front Panel Rating with Integrated Gasket
 NFPA110 Compatible

* Represents standard product only. Consult Factory/MTU Onsite Energy Distributor for additional configurations.

APPLICATION DATA

// Engine

Manufacturer	MTU
Model	8V1600G80S
Type	4-Cycle
Arrangement	8-V
Displacement: L (Cu In)	14 (854)
Bore: cm (in)	12.2 (4.8)
Stroke: cm (in)	15 (5.91)
Compression Ratio	17.5:1
Rated RPM	1,800
Engine Governor	Electronic Isochronous (ADEC)
Max Power: kWm (bhp)	448 (600)
Speed Regulation	±0.25%
Air Cleaner	Dry

// Liquid Capacity (Lubrication)

Total Oil System: L (gal)	46 (12.2)
Engine Jacket Water Capacity: L (gal)	50 (13.2)
System Coolant Capacity: L (gal)	80.3 (21.2)

// Electrical

Electric Volts DC	24
Cold Cranking Amps Under -17.8 °C (0 °F)	1,000

// Fuel System

Fuel Supply Connection Size	#10 JIC 37° Female M20 x 1.5 Male Adapter Provided
Fuel Return Connection Size	#6 JIC 37° Female M14 x 1.5 Male Adapter Provided
Maximum Fuel Lift: m (ft)	5 (16)
Recommended Fuel	Diesel #2
Total Fuel Flow: L/hr (gal/hr)	402 (123)

// Fuel Consumption

	STANDBY
At 100% of Power Rating: L/hr (gal/hr)	106 (28)
At 75% of Power Rating: L/hr (gal/hr)	87 (23)
At 50% of Power Rating: L/hr (gal/hr)	66 (17.5)

// Cooling - Radiator System

	STANDBY
Ambient Capacity of Radiator: °C (°F)	50 (122)
Max. Restriction of Cooling Air, Intake, and Discharge Side of Rad.: kPa (in. H ₂ O)	0.125 (0.5)
Water Pump Capacity: L/min (gpm)	362 (95)
Heat Rejection to Coolant: kW (BTUM)	205 (11,658)
Heat Rejection to After Cooler: kW (BTUM)	120 (6,824)
Heat Radiated to Ambient: kW (BTUM)	18 (1,024)

// Air Requirements

	STANDBY
Aspirating: *m ³ /min (SCFM)	30 (1,060)
Air Flow Required for Rad. Cooled Unit: *m ³ /min (SCFM)	510 (18,010)
Remote Cooled Applications; Air Flow Required for Dissipation of Radiated Gen-set Heat for a Max of 25 °F Rise: *m ³ /min (SCFM)	65 (2,309)

* Air density = 1.184 kg/m³ (0.0739 lbm/ft³)

// Exhaust System

	STANDBY
Gas Temp. (Stack): °C (°F)	478 (892)
Gas Volume at Stack Temp: m ³ /min (CFM)	78 (2,755)
Maximum Allowable Back Pressure: kPa (in. H ₂ O)	15 (61)

WEIGHTS AND DIMENSIONS

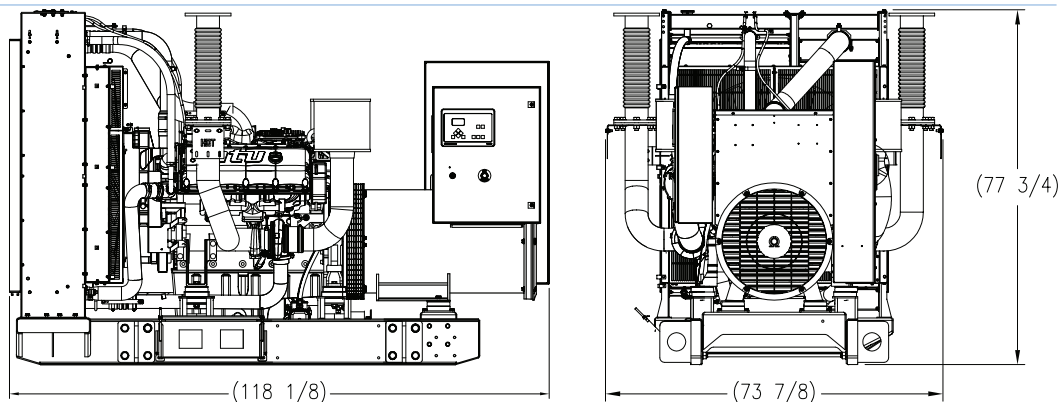

Drawing above for illustration purposes only, based on standard open power 480 volt engine-generator set. Lengths may vary with other voltages. Do not use for installation design. See website for unit specific template drawings.

System

Open Power Unit (OPU)

Dimensions (L x W x H)

3,001 x 1,877 x 1,975 mm (118.13 x 73.88 x 77.75 in)

Weight (dry/less tank)

3,652 kg (8,050 lb)

Weights and dimensions are based on open power units and are estimates only. Consult the factory for accurate weights and dimensions for your specific engine-generator set.

SOUND DATA

Unit Type

Level 0: Open Power Unit (dBA)

Standby Full Load

C/F

Sound data is provided at 7 m (23 ft). Engine-generator set tested in accordance with ISO 8528-10 and with infinite exhaust.

EMISSIONS DATA

NO_x + NMHC

5.01

CO

0.52

PM

0.04

All units are in g/hp-hr and at 100% load.

Emission levels of the engine may vary as a function of ambient temperature, barometric pressure, humidity, fuel type and quality, installation parameters, measuring instrumentation, etc. The data provided are laboratory results from one engine representing this rating. The data was obtained under controlled environmental conditions with calibrated instrumentation traceable to the United States National Bureau of Standards and in compliance with US EPA regulations found within 40 CFR Part 89. The weighted cycle value (not shown) from each engine is guaranteed to be below the US EPA Standards at the US EPA defined conditions.

RATING DEFINITIONS AND CONDITIONS

// Standby ratings apply to installations served by a reliable utility source. The standby rating is applicable to varying loads for the duration of a power outage. No overload capability for this rating. Ratings are in accordance with ISO 8528-1, ISO-3046-1, BS 5514, AS 2789, and DIN 6271.

// Deration Factor:

Altitude: Consult your local MTU Onsite Energy Power Generation Distributor for altitude derations.

Temperature: Consult your local MTU Onsite Energy Power Generation Distributor for temperature derations.

Materials and specifications subject to change without notice.

C/F = Consult Factory/MTU Onsite Energy Distributor