

# DIESEL ENGINE-GENERATOR SET

## AIR CHARGE-AIR COOLING

325 kWe / 60 Hz / Prime  
208 - 600V

(Reference DS350D6S for Standby Rating Technical Data)



### SYSTEM RATINGS

Prime	DP325D6SPA	DP325D6SJA	DP325D6SVA	DP325D6SWA	DP325D6SRA	DP325D6SNA
Voltage (L-L)	208V**	240V**	380V	440V	480V**	600V**
Phase	3	3	3	3	3	3
PF	0.8	0.8	0.8	0.8	0.8	0.8
Hz	60	60	60	60	60	60
kW	325	325	325	325	325	325
kVA	407	407	407	407	407	407
AMPS	1128	977	617	533	489	391
skVA@30%						
Voltage Dip	750	750	635	850	1040	1100
Generator Model	433CSL6216	433CSL6216	433CSL6216	433CSL6216	433CSL6216	433PSL6248
Temp Rise	105 °C/40 °C	105 °C/40 °C	105 °C/40 °C	105 °C/40 °C	105 °C/40 °C	105 °C/40 °C
Connection	12 LEAD LOW WYE	12 LEAD HI DELTA	12 LEAD HI WYE	12 LEAD HI WYE	12 LEAD HI WYE	4 LEAD WYE

\*\* UL 2200 Offered

### CERTIFICATIONS AND STANDARDS

// Emissions – EPA Tier 3 Certified

// Engine-generator set is designed and manufactured in facilities certified to standards ISO 9001:2008 and ISO 14001:2004

// UL 2200 / CSA – Optional

- UL 2200 Listed
- CSA Certified

// Performance Assurance Certification (PAC)

- Engine-Generator Set Tested to ISO 8528-5 for Transient Response
- Verified product design, quality and performance integrity
- All engine systems are prototype and factory tested

// Power Rating

- Accepts Rated Load in One Step Per NFPA 110
- Permissible average power output during 24 hours of operation is approved up to 75%.

## STANDARD FEATURES\*

- // MTU Onsite Energy is a single source supplier
  - // Global Product Support
  - // 2 Year Standard Warranty
  - // 8V1600 Diesel Engine
    - 14.0 Liter Displacement
    - Common Rail Fuel Injection
    - 4-Cycle
  - // Engine-generator resilient mounted
  - // Complete Range of Accessories
- // Generator
    - Brushless, Rotating Field Generator
    - PMG (Permanent Magnet Generator) supply to regulator (570 frame only)
    - 300% Short Circuit Capability
    - 2/3 Pitch Windings
  - // Digital Control Panel(s)
    - UL Recognized, CSA Certified, NFPA 110
    - Complete System Metering
    - LCD Display
  - // Cooling System
    - Integral Set-Mounted
    - Engine Driven Fan

## STANDARD EQUIPMENT\*

### // Engine

Air Cleaners  
 Oil Pump  
 Oil Drain Extension & S/O Valve  
 Full Flow Oil Filters  
 Closed Crankcase Ventilation  
 Jacket Water Pump  
 Thermostats  
 Blower Fan & Fan Drive  
 Radiator - Unit Mounted  
 Electric Starting Motor - 24V  
 Governor - Electronic Isochronous  
 Base - Formed Steel  
 SAE Flywheel & Bell Housing  
 Charging Alternator - 24V  
 Battery Box & Cables  
 Flexible Fuel Connectors  
 Flexible Exhaust Connection  
 EPA Certified Engine

### // Generator

NEMA MG1, IEEE and ANSI standards compliance for temperature rise and motor starting  
 Sustained short circuit current of up to 300% of the rated current for up to 10 seconds  
 Self-Ventilated  
 Superior Voltage Waveform  
 Digital, Solid State, Volts-per-Hertz Regulator  
 No Load to Full Load Regulation

Brushless Alternator with Brushless Pilot Exciter  
 4 Pole, Rotating Field  
 105 °C Maximum Prime Temperature Rise  
 1 Bearing, Sealed  
 Flexible Coupling  
 Full Amortisseur Windings  
 125% Rotor Balancing  
 3-Phase Voltage Sensing  
 ±0.25% Voltage Regulation (570 frame)  
 ±1% Voltage Regulation (430 frame)  
 100% of Rated Load - One Step  
 3% Maximum Harmonic Content

### // Digital Control Panel(s)

Digital Metering  
 Engine Parameters  
 Generator Protection Functions  
 Engine Protection  
 CAN Bus ECU Communications  
 Windows-Based Software  
 Multilingual Capability  
 Remote Communications to RDP-110 Remote Annunciator  
 16 Programmable Contact Inputs  
 Up to 11 Contact Outputs  
 UL Recognized, CSA Certified, CE Approved  
 Event Recording  
 IP 54 Front Panel Rating with Integrated Gasket  
 NFPA110 Compatible

\* Represents standard product only. Consult Factory/MTU Onsite Energy Distributor for additional configurations.

## APPLICATION DATA

### // Engine

Manufacturer	MTU
Model	8V1600G10S
Type	4-Cycle
Arrangement	8-V
Displacement: L (Cu In)	14 (854)
Bore: cm (in)	12.2 (4.8)
Stroke: cm (in)	15 (5.91)
Compression Ratio	17.5:1
Rated RPM	1,800
Engine Governor	Electronic Isochronous (ADEC)
Max Power: kWm (bhp)	371 (497)
Speed Regulation	±0.25%
Air Cleaner	Dry

### // Liquid Capacity (Lubrication)

Total Oil System: L (gal)	46 (12.2)
Engine Jacket Water Capacity: L (gal)	50 (13.2)
System Coolant Capacity: L (gal)	80.3 (21.2)

### // Electrical

Electric Volts DC	24
Cold Cranking Amps Under -17.8 °C (0 °F)	1,000

### // Fuel System

Fuel Supply Connection Size	#10 JIC 37° Female M20 x 1.5 Male Adapter Provided
Fuel Return Connection Size	#6 JIC 37° Female M14 x 1.5 Male Adapter Provided
Maximum Fuel Lift: m (ft)	5 (16)
Recommended Fuel	Diesel #2
Total Fuel Flow: L/hr (gal/hr)	402 (123)

### // Fuel Consumption

	PRIME
At 100% of Power Rating: L/hr (gal/hr)	93 (24.5)
At 75% of Power Rating: L/hr (gal/hr)	78 (20.6)
At 50% of Power Rating: L/hr (gal/hr)	55 (14.5)

### // Cooling - Radiator System

	PRIME
Ambient Capacity of Radiator: °C (°F)	50 (122)
Max. Restriction of Cooling Air, Intake, and Discharge Side of Rad.: kPa (in. H <sub>2</sub> O)	0.125 (0.5)
Water Pump Capacity: L/min (gpm)	362 (95)
Heat Rejection to Coolant: kW (BTUM)	190 (10,805)
Heat Rejection to After Cooler: kW (BTUM)	95 (5,403)
Heat Radiated to Ambient: kW (BTUM)	16 (910)

### // Air Requirements

	PRIME
Aspirating: *m <sup>3</sup> /min (SCFM)	30 (1,060)
Air Flow Required for Rad.	
Cooled Unit: *m <sup>3</sup> /min (SCFM)	510 (18,010)
Remote Cooled Applications; Air Flow Required for Dissipation of Radiated Gen-set Heat for a Max of 25 °F Rise: *m <sup>3</sup> /min (SCFM)	58 (2,052)

\* Air density = 1.184 kg/m<sup>3</sup> (0.0739 lbm/ft<sup>3</sup>)

### // Exhaust System

	PRIME
Gas Temp. (Stack): °C (°F)	460 (860)
Gas Volume at Stack	
Temp: m <sup>3</sup> /min (CFM)	84 (2,966)
Maximum Allowable Back Pressure: kPa (in. H <sub>2</sub> O)	15 (61)

## WEIGHTS AND DIMENSIONS

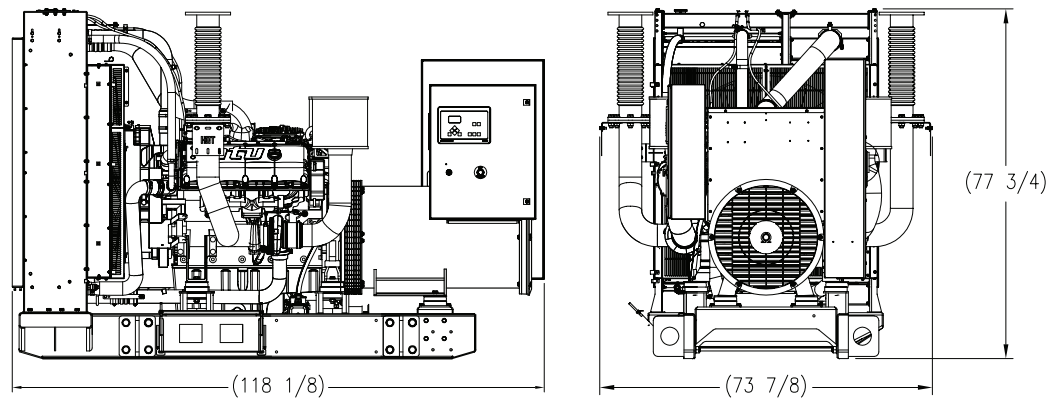

Drawing above for illustration purposes only, based on standard open power 480 volt engine-generator set. Lengths may vary with other voltages. Do not use for installation design. See website for unit specific template drawings.

### System

Open Power Unit (OPU)

### Dimensions (L x W x H)

3,001 x 1,877 x 1,975 mm (118.13 x 73.88 x 77.75 in)

### Weight (dry/less tank)

3,652 kg (8,050 lb)

Weights and dimensions are based on open power units and are estimates only. Consult the factory for accurate weights and dimensions for your specific engine-generator set.

## SOUND DATA

### Unit Type

Level 0: Open Power Unit (dBA)

### Prime Full Load

C/F

Sound data is provided at 7 m (23 ft). Engine-generator set tested in accordance with ISO 8528-10 and with infinite exhaust.

## EMISSIONS DATA

### NO<sub>x</sub> + NMHC

4.06

### CO

0.52

### PM

0.05

### All units are in g/hp-hr and at 100% load.

Emission levels of the engine may vary as a function of ambient temperature, barometric pressure, humidity, fuel type and quality, installation parameters, measuring instrumentation, etc. The data provided are laboratory results from one engine representing this rating. The data was obtained under controlled environmental conditions with calibrated instrumentation traceable to the United States National Bureau of Standards and in compliance with US EPA regulations found within 40 CFR Part 89. The weighted cycle value (not shown) from each engine is guaranteed to be below the US EPA Standards at the US EPA defined conditions.

## RATING DEFINITIONS AND CONDITIONS

// Prime power ratings apply to installations where utility power is unavailable or unreliable. At varying load, the number of generator set operating hours is unlimited. A 10% overload capacity is available for one hour in twelve. Ratings are in accordance with ISO 8528-1, ISO 3046-1, BS 5514, AS 2789, and DIN 6271.

// Deration Factor:

**Altitude:** Consult your local MTU Onsite Energy Power Generation Distributor for altitude derations.

**Temperature:** Consult your local MTU Onsite Energy Power Generation Distributor for temperature derations.

Materials and specifications subject to change without notice.

C/F = Consult Factory/MTU Onsite Energy Distributor