

GAS ENGINE-GENERATOR SET

80-GC6NLT1

80 kWe / 60 Hz / Standby
208 - 600V



SYSTEM RATINGS

Standby

Voltage (L-L)	240V**	240V**	208V**	240V**	480V**	600V**
Phase	1	1	3	3	3	3
PF	1.0	1.0	0.8	0.8	0.8	0.8
Hz	60	60	60	60	60	60
Natural Gas						
Ratings: Amps	333	333	278	241	120	96
Natural Gas						
Ratings: kW/kVA	80/80	80/80	80/100	80/100	80/100	80/100
LP Gas						
Ratings: Amps	333	333	278	241	120	96
LP Gas						
Ratings: kW/kVA	80/80	80/80	80/100	80/100	80/100	80/100
skVA@30%						
Voltage Dip	157	310	177	177	237	237
Generator Model*	363CSL1607	363CSL1617	362CSL1604	362CSL1604	362CSL1604	362PSL1635
Temp Rise	130 °C/40 °C	130 °C/40 °C	130 °C/40 °C	130 °C/40 °C	130 °C/40 °C	130 °C/40 °C
Connection	12 LEAD ZIG-ZAG	4 LEAD	12 LEAD LOW WYE	12 LEAD HI DELTA	12 LEAD HI WYE	4 LEAD WYE

* The Generator Model Number identified in the table is for standard C Series Configuration. Consult the factory for alternate configuration.

** UL 2200 Offered

CERTIFICATIONS AND STANDARDS

// **Engine-generator set is designed and manufactured in facilities certified to standards ISO 9001:2008 and ISO 14001:2004**

// **Power Rating**

- Accepts Rated Load in One Step Per NFPA 110

// **UL 2200 / CSA – Optional**

- UL 2200 Listed
- CSA Certified

// **Performance Assurance Certification (PAC)**

- Engine-Generator Set Tested to ISO 8528-5 for Transient Response
- Verified product design, quality and performance integrity
- All engine systems are prototype and factory tested

STANDARD FEATURES*

- // MTU Onsite Energy is a single source supplier
- // Global Product Support
- // 2 Year Standard Warranty
- // 8.1 L Engine
 - 8.1 Liter Displacement
 - 4-Cycle
- // 3-Way Catalyst
- // Engine-generator resilient mounted
- // Complete Range of Accessories

- // Generator
 - Brushless, Rotating Field Generator
 - 300% Short Circuit Capability
 - 2/3 Pitch Windings
 - 570 frames and larger
- // Digital Control Panel(s)
 - UL Recognized, CSA Certified, NFPA 110
 - Complete System Metering
 - LCD Display
- // Cooling System
 - Integral Set-Mounted
 - Engine Driven Fan

STANDARD EQUIPMENT*

// Engine

Air Cleaners
 Oil Pump
 Oil Drain Extension & S/O Valve
 Full Flow Oil Filter
 Jacket Water Pump
 Thermostat
 Blower Fan & Fan Drive
 Radiator - Unit Mounted
 Electric Starting Motor - 12V
 Governor - Electronic Isochronous
 Base - Formed Steel
 SAE Flywheel & Bell Housing
 Charging Alternator - 12V
 Battery Box & Cables
 Flexible Fuel Connectors
 Flexible Exhaust Connection
 EPA Certified Engine

// Generator

NEMA MG1, IEEE and ANSI standards compliance for temperature rise and motor starting
 Sustained short circuit current of up to 300% of the rated current for up to 10 seconds
 Self-Ventilated and Drip-Proof
 Superior Voltage Waveform
 Digital, Solid State, Volts-per-Hertz Regulator
 No Load to Full Load Regulation

Brushless Alternator with Brushless Pilot Exciter
 4 Pole, Rotating Field
 130 °C Maximum Standby Temperature Rise
 1 Bearing, Sealed
 Flexible Coupling
 Full Amortisseur Windings
 125% Rotor Balancing
 3-Phase Voltage Sensing
 ± 1% Voltage Regulation
 100% of Rated Load - One Step
 3% Maximum Harmonic Content

// Digital Control Panel(s)

Digital Metering
 Engine Parameters
 Generator Protection Functions
 Engine Protection
 SAE J1939 Engine ECU Communications
 Windows-Based Software
 Multilingual Capability
 Remote Communications to RDP-110 Remote Annunciator
 16 Programmable Contact Inputs
 Up to 11 Contact Outputs
 UL Recognized, CSA Certified, CE Approved
 Event Recording
 IP 54 Front Panel Rating with Integrated Gasket
 NFPA110 Compatible

* Represents standard product only. Consult Factory/MTU Onsite Energy Distributor for additional configurations.

APPLICATION DATA

// Engine

Manufacturer	GM
Model	8.1L
Type	4-Cycle
Arrangement	8-V
Displacement: L (in ³)	8.1 (496)
Bore: cm (in)	10.8 (4.25)
Stroke: cm (in)	11.1 (4.37)
Compression Ratio	9.1:1
Rated RPM	1,800
Engine Governor	Bosch
Maximum Power: kWm (bhp)	122.6 (164.4)
Speed Regulation	C/F
Air Cleaner	Dry

// Liquid Capacity (Lubrication)

Total Oil System: L (gal)	7.6 (2)
Engine Jacket Water Capacity: L (gal)	13.6 (3.6)
System Coolant Capacity: L (gal)	31.8 (8.4)

// Electrical

Electric Volts DC	12
Cold Cranking Amps Under -17.8 °C (0 °F)	600

// Fuel Inlet

Fuel Supply Connection Size	1 1/2" NPT
Fuel Supply Pressure: mm H ₂ O (in. H ₂ O)	178-279 (7-11)

// Fuel Consumption (NG-1000 BTU/ft³ / LP-2500 BTU/ft³)

	NG	LPG
At 100% of Power Rating: m ³ /hr (ft ³ /hr)	25.5 (900)	11.3 (398)
At 75% of Power Rating: m ³ /hr (ft ³ /hr)	18.9 (667)	8.4 (295)
At 50% of Power Rating: m ³ /hr (ft ³ /hr)	12.7 (448)	5.6 (198)

// Cooling - Radiator System

Ambient Capacity of Radiator: °C (°F)	50 (122)
Maximum Restriction of Cooling Air, Intake, and Discharge Side of Rad.: kPa (in. H ₂ O)	0.12 (0.5)
Water Pump Capacity: L/min (gpm)	140.1 (37)
Heat Rejection to Coolant: kW (BTUM)	72.8 (4,141)
Heat Radiated to Ambient: kW (BTUM)	23 (1,305)

// Air Requirements

Aspirating: *m ³ /min (SCFM)	7.3 (258.3)
Air Flow Required for Rad.	
Cooled Unit: *m ³ /min (SCFM)	284 (10,030)
Remote Cooled Applications; Air Flow Required for Dissipation of Radiated Gen-set Heat For a Max of 25 °F Rise: *m ³ /min (SCFM)	83.4 (2,944)

* Air density = 1.184 kg/m³ (0.0739 lbm/ft³)

// Exhaust System

Gas Temp. (Stack): °C (°F)	704.4 (1,300)
Gas Volume at Stack Temp: m ³ /min (CFM)	23.6 (834)
Maximum Allowable Back Pressure: kPa (in. H ₂ O)	10 (40)

WEIGHTS AND DIMENSIONS

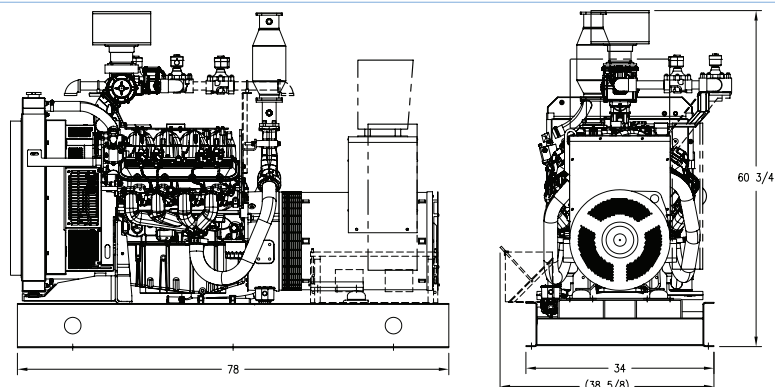

Drawing above for illustration purposes only, based on standard open power 480 volt engine-generator set. Lengths may vary with other voltages. Do not use for installation design. See website for unit specific template drawings.

System	Dimensions (L x W x H)	Weight (dry)
OPU	1,981 x 864 x 1,543 mm (78 x 34 x 60.75 in)	976 kg (2,150 lb)

Weights and dimensions are based on open power units and are estimates only. Consult the factory for accurate weights and dimensions for your specific engine-generator set.

SOUND DATA

Unit Type	Standby Full Load
Level 0: Open Power Unit (dBA)	C/F
WPE - No Sound Attenuation (dBA)	C/F
CQE (dBA)	C/F

Sound data is provided at 7 m (23 ft). Engine-generator set tested in accordance with ISO 8528-10 and with infinite exhaust.

EMISSIONS DATA

Fuel Type	THC + NO _x	CO
Natural Gas	0.13	0.17
Liquid Propane	0.07	0.44

All units are in g/hp-hr.

Engine meets EPA 40 CFR Part 60/1048 specifications.

RATING DEFINITIONS AND CONDITIONS

// Standby ratings apply to installations served by a reliable utility source. The standby rating is applicable to varying loads for the duration of a power outage. No overload capability for this rating. Ratings are in accordance with ISO 3046-1, BS 5514, AS 2789, and DIN 6271.

// Deration Factor:

Altitude: Consult your local MTU Onsite Energy Power Generation Distributor for altitude derations.

Temperature: Consult your local MTU Onsite Energy Power Generation Distributor for temperature derations.

Materials and specifications subject to change without notice.

C/F = Consult Factory/MTU Onsite Energy Distributor