

DIESEL ENGINE-GENERATOR SET

680-XC6DT2

680 kWe / 60 Hz / Prime
208 - 4160V

(Reference 750-XC6DT2 for Standby Rating Technical Data)



SYSTEM RATINGS

Prime

Voltage (L-L)	208V**	240V**	480V**	600V**	4160V
Phase	3	3	3	3	3
PF	0.8	0.8	0.8	0.8	0.8
Hz	60	60	60	60	60
kW	680	680	680	680	680
kVA	850	850	850	850	850
AMPS	2359	2045	1022	818	118
skVA@30%					
Voltage Dip	2600	2600	2120	3050	1850
Generator Model*	574RSL4037	574RSL4037	573RSL4035	574RSS4278	574FSM4358
Temp Rise	105 °C/40 °C	105 °C/40 °C	105 °C/40 °C	105 °C/40 °C	105 °C/40 °C
Connection	12 LEAD LOW WYE	12 LEAD HI DELTA	12 LEAD HI WYE	4 LEAD WYE	6 LEAD WYE

* The Generator Model Number identified in the table is for standard C Series Configuration. Consult the factory for alternate configuration.

** UL 2200 Offered

CERTIFICATIONS AND STANDARDS

// **Emissions** – EPA Tier 2 Certified

// **Engine-generator set is designed and manufactured in facilities certified to standards ISO 9001:2008 and ISO 14001:2004**

// **UL 2200 / CSA – Optional**

- UL 2200 Listed
- CSA Certified

// **Performance Assurance Certification (PAC)**

- Engine-Generator Set Tested to ISO 8528-5 for Transient Response
- Verified product design, quality and performance integrity
- All engine systems are prototype and factory tested

// **Power Rating**

- Accepts Rated Load in One Step Per NFPA 110
- Permissible average power output during 24 hours of operation is approved up to 75%.

STANDARD FEATURES*

- // MTU Onsite Energy is a single source supplier
- // Global Product Support
- // 2 Year Standard Warranty
- // 12V 2000 Diesel Engine
 - 23.9 Liter Displacement
 - Electronic Unit Pump Injection
 - 4-Cycle
- // Complete Range of Accessories
- // Generator
 - Brushless, Rotating Field Generator
 - PMG (Permanent Magnet Generator) supply to regulator
 - 300% Short Circuit Capability
 - 2/3 Pitch Windings
 - Standard for 570 frame and larger
 - Optional for 430 frame and smaller
- // Digital Control Panel(s)
 - UL Recognized, CSA Certified, NFPA 110
 - Complete System Metering
 - LCD Display
- // Cooling System
 - Integral Set-Mounted
 - Engine Driven Fan

STANDARD EQUIPMENT*

// Engine

Air Cleaners
 Oil Pump
 Oil Drain Extension & S/O Valve
 Full Flow Oil Filter
 Closed Crankcase Ventilation
 Jacket Water Pump
 Inter Cooler Water Pump
 Thermostats
 Blower Fan & Fan Drive
 Radiator - Unit Mounted
 Electric Starting Motor - 24V
 Governor - Electronic Isochronous
 Base - Structural Steel
 SAE Flywheel & Bell Housing
 Charging Alternator - 24V
 Battery Box & Cables
 Flexible Fuel Connectors
 Flexible Exhaust Connection
 EPA Certified Engine

// Generator

NEMA MG1, IEEE and ANSI standards compliance for temperature rise and motor starting
 Sustained short circuit current of up to 300% of the rated current for up to 10 seconds
 Self-Ventilated and Drip-Proof
 Superior Voltage Waveform
 Digital, Solid State, Volts-per-Hertz Regulator

No Load to Full Load Regulation
 Brushless Alternator with Brushless Pilot Exciter
 4 Pole, Rotating Field
 105 °C Maximum Prime Temperature Rise
 1 Bearing, Sealed
 Flexible Coupling
 Full Amortisseur Windings
 125% Rotor Balancing
 3-Phase Voltage Sensing
 ±0.25% Voltage Regulation
 100% of Rated Load - One Step
 3% Maximum Harmonic Content

// Digital Control Panel(s)

Digital Metering
 Engine Parameters
 Generator Protection Functions
 Engine Protection
 CAN Bus ECU Communications
 Windows-Based Software
 Multilingual Capability
 Remote Communications to RDP-110 Remote Annunciator
 16 Programmable Contact Inputs
 Up to 11 Contact Outputs
 UL Recognized, CSA Certified, CE Approved
 Event Recording
 IP 54 Front Panel Rating with Integrated Gasket
 NFPA110 Compatible

* Represents standard product only. Consult Factory/MTU Onsite Energy Distributor for additional configurations.

APPLICATION DATA

// Engine

Manufacturer	MTU
Model	12V 2000 G85TB
Type	4-Cycle
Arrangement	12-V
Displacement: L (in ³)	23.9 (1,457)
Bore: cm (in)	13 (5.1)
Stroke: cm (in)	15 (5.9)
Compression Ratio	16:1
Rated RPM	1,800
Engine Governor	Electronic Isochronous (ADEC)
Maximum Power: kWm (bhp)	810 (1,086)
Speed Regulation	±0.25%
Air Cleaner	Dry

// Liquid Capacity (Lubrication)

Total Oil System: L (gal)	77 (20.3)
Engine Jacket Water Capacity: L (gal)	110 (29.1)
After Cooler Water Capacity: L (gal)	20 (5.3)
System Coolant Capacity: L (gal)	274 (72.4)

// Electrical

Electric Volts DC	24
Cold Cranking Amps Under -17.8 °C (0 °F)	1,750

// Fuel System

Fuel Supply Connection Size	3/4" NPT
Fuel Return Connection Size	1/4" NPT
Maximum Fuel Lift: m (ft)	3 (10)
Recommended Fuel	Diesel #2
Total Fuel Flow: L/hr (gal/hr)	480.7 (127)

// Fuel Consumption

	PRIME
At 100% of Power Rating: L/hr (gal/hr)	199.1 (52.6)
At 75% of Power Rating: L/hr (gal/hr)	149.9 (39.6)
At 50% of Power Rating: L/hr (gal/hr)	101.4 (26.8)

// Cooling - Radiator System

	PRIME
Ambient Capacity of Radiator: °C (°F)	40 (104)
Maximum Restriction of Cooling Air, Intake, and Discharge Side of Rad.: kPa (in. H ₂ O)	0.12 (0.5)
Water Pump Capacity: L/min (gpm)	833 (220)
After Cooler Pump Capacity: L/min (gpm)	257 (68)
Heat Rejection to Coolant: kW (BTUM)	280 (15,923)
Heat Rejection to After Cooler: kW (BTUM)	245 (13,932)
Heat Radiated to Ambient: kW (BTUM)	76.5 (4,350)

// Air Requirements

	PRIME
Aspirating: *m ³ /min (SCFM)	2,225 (63)
Air Flow Required for Rad.	
Cooled Unit: *m ³ /min (SCFM)	1,132 (39,997)
Remote Cooled Applications;	
Air Flow Required for Dissipation of Radiated Gen-set Heat for a Max of 25 °F Rise: *m ³ /min (SCFM)	278 (9,811)

* Air density = 1.184 kg/m³ (0.0739 lbm/ft³)

// Exhaust System

	PRIME
Gas Temp. (Stack): °C (°F)	560 (1,040)
Gas Volume at Stack	
Temp: m ³ /min (CFM)	160 (5,721)
Maximum Allowable	
Back Pressure: kPa (in. H ₂ O)	8.5 (34.1)

WEIGHTS AND DIMENSIONS

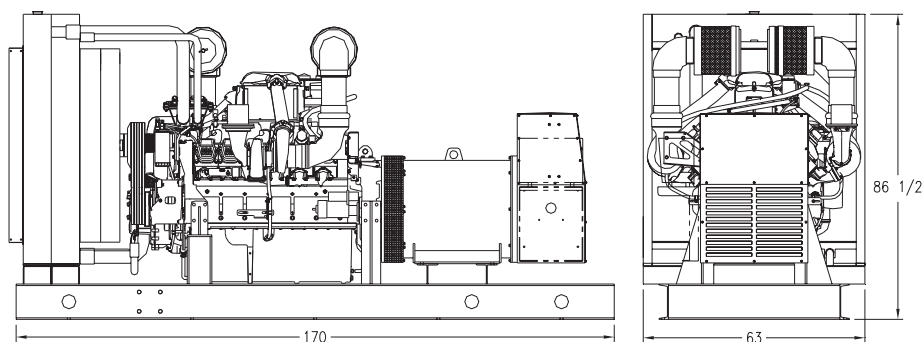

Drawing above for illustration purposes only, based on standard open power 480 volt engine-generator set. Lengths may vary with other voltages. Do not use for installation design. See website for unit specific template drawings.

System

OPU

Dimensions (L x W x H)

4,320 x 1,600 x 2,200 mm (170 x 63 x 86.5 in)

Weight (less tank)

5,592 kg (12,328 lb)

Weights and dimensions are based on open power units and are estimates only. Consult the factory for accurate weights and dimensions for your specific engine-generator set.

SOUND DATA

Unit Type

Level 0: Open Power Unit (dBA)

Prime Full Load

98.5

Sound data is provided at 7 m (23 ft). Engine-generator set tested in accordance with ISO 8528-10 and with infinite exhaust.

EMISSIONS DATA

NO_x + NMHC

4.68

CO

0.44

PM

0.02

All units are in g/hp-hr and at 100% load.

Emission levels of the engine may vary as a function of ambient temperature, barometric pressure, humidity, fuel type and quality, installation parameters, measuring instrumentation, etc. The data provided are laboratory results from one engine representing this rating. The data was obtained under controlled environmental conditions with calibrated instrumentation traceable to the United States National Bureau of Standards and in compliance with US EPA regulations found within 40 CFR Part 89. The weighted cycle value (not shown) from each engine is guaranteed to be below the US EPA Standards at the US EPA defined conditions.

RATING DEFINITIONS AND CONDITIONS

// Prime power ratings apply to installations where utility power is unavailable or unreliable. At varying load, the number of generator set operating hours is unlimited. A 10% overload capacity is available for one hour in twelve. Ratings are in accordance with ISO 8528-1, ISO 3046-1, BS 5514, AS 2789, and DIN 6271.

// Deration Factor:

Altitude: Consult your local MTU Onsite Energy Power Generation Distributor for altitude derations.

Temperature: Consult your local MTU Onsite Energy Power Generation Distributor for temperature derations.

Materials and specifications subject to change without notice.

C/F = Consult Factory/MTU Onsite Energy Distributor

// **Tognum Group Companies:** Europe / Middle East / Africa / MTU Onsite Energy / 88040 Friedrichshafen / Germany / Phone + 49 7541 90 7060 / Fax +49 7541 90 7084 / powergenregion1@mtu-online.com // Asia / Australia / Pacific / MTU Onsite Energy / 1, Benoi Place / Singapore 629923 / Republic of Singapore / Phone + 65 6861 5922 / Fax + 65 6861 3615 / powergenregion2@mtu-online.com // USA / Canada / Latin America / Mexico / MTU Onsite Energy Corporation / 100 Power Drive / Mankato, Minnesota 56001 / USA / Phone + 1 507 625 7973 / Fax + 1 507 625 2968 / powergenregion3@mtu-online.com